

TAS5036B

Six Channel Digital Audio PWM Processor

Data Manual

IMPORTANT NOTICE

Texas Instruments Incorporated and its subsidiaries (TI) reserve the right to make corrections, modifications, enhancements, improvements, and other changes to its products and services at any time and to discontinue any product or service without notice. Customers should obtain the latest relevant information before placing orders and should verify that such information is current and complete. All products are sold subject to TI's terms and conditions of sale supplied at the time of order acknowledgment.

TI warrants performance of its hardware products to the specifications applicable at the time of sale in accordance with TI's standard warranty. Testing and other quality control techniques are used to the extent TI deems necessary to support this warranty. Except where mandated by government requirements, testing of all parameters of each product is not necessarily performed.

TI assumes no liability for applications assistance or customer product design. Customers are responsible for their products and applications using TI components. To minimize the risks associated with customer products and applications, customers should provide adequate design and operating safeguards.

TI does not warrant or represent that any license, either express or implied, is granted under any TI patent right, copyright, mask work right, or other TI intellectual property right relating to any combination, machine, or process in which TI products or services are used. Information published by TI regarding third-party products or services does not constitute a license from TI to use such products or services or a warranty or endorsement thereof. Use of such information may require a license from a third party under the patents or other intellectual property of the third party, or a license from TI under the patents or other intellectual property of TI.

Reproduction of information in TI data books or data sheets is permissible only if reproduction is without alteration and is accompanied by all associated warranties, conditions, limitations, and notices. Reproduction of this information with alteration is an unfair and deceptive business practice. TI is not responsible or liable for such altered documentation.

Resale of TI products or services with statements different from or beyond the parameters stated by TI for that product or service voids all express and any implied warranties for the associated TI product or service and is an unfair and deceptive business practice. TI is not responsible or liable for any such statements.

Mailing Address:

Texas Instruments
Post Office Box 655303
Dallas, Texas 75265

Contents

<i>Section</i>	<i>Page</i>
1 Introduction	1
1.1 Features	1
1.2 Functional Block Diagram	2
1.3 Terminal Assignments	3
1.4 Ordering Information	4
1.5 Terminal Functions	4
2 Architecture Overview	6
2.1 Clock and Serial Data Interface	6
2.1.1 Normal-Speed, Double-Speed, and Quad-Speed Selection	6
2.1.2 Clock Master/Slave Mode (M_S)	7
2.1.3 Clock Master Mode	7
2.1.4 Clock Slave Mode	8
2.1.5 PLL Filter	10
2.1.6 DCLK	10
2.1.7 Serial Data Interface	10
2.2 Reset, Power Down, and Status	15
2.2.1 Reset— $\overline{\text{RESET}}$	15
2.2.2 Power Down— $\overline{\text{PDN}}$	16
2.2.3 General Status Registers	16
2.3 Signal Processing	18
2.3.1 Volume Control	18
2.3.2 Mute	19
2.3.3 Auto Mute	19
2.3.4 Individual Channel Mute	19
2.3.5 De-Emphasis Filter	19
2.4 Pulse Width Modulator (PWM)	20
2.4.1 Clipping Indicator	20
2.4.2 Error Recovery	20
2.4.3 Individual Channel Error Recovery	21
2.4.4 PWM DC-Offset Correction	21
2.4.5 Interchannel Delay	21
2.4.6 ABD Delay	21
2.4.7 PWM/H-Bridge and Discrete H-Bridge Driver Interface	22
2.5 I ² C Serial Control Interface	22
2.5.1 Single Byte Write	23
2.5.2 Multiple Byte Write	23
2.5.3 Single Byte Read	24
2.5.4 Multiple Byte Read	24
3 Serial Control Interface Register Definitions	25
3.1 General Status Register (x00)	26
3.2 Error Status Register (x01)	26
3.3 System Control Register 0 (x02)	26
3.4 System Control Register 1 (x03)	27
3.5 Error Recovery Register (x04)	27
3.6 Automute Delay Register (x05)	28
3.7 DC-Offset Control Registers (x06–x0B)	28

3.8	Interchannel Delay Registers (x0C–x11)	28
3.9	ABD Delay Register (x12)	28
3.10	Individual Channel Mute Register (x19)	29
4	System Procedures for Initialization, Changing Data Rates, and Switching Between Master and Slave Modes	30
4.1	System Initialization	30
4.2	Data Sample Rate	31
4.3	Changing Between Master and Slave Modes	34
5	Specifications	36
5.1	Absolute Maximum Ratings Over Operating Temperature Ranges	36
5.2	Recommended Operating Conditions (Fs = 48 kHz)	36
5.3	Electrical Characteristics Over Recommended Operating Conditions	36
5.3.1	Static Digital Specifications Over Recommended Operating Conditions	36
5.3.2	Digital Interpolation Filter and PWM Modulator Over Recommended Operating Conditions Fs = 48 kHz	36
5.3.3	TAS5036B/TAS5182 System Performance Measured at the Speaker Terminals Over Recommended Operating Conditions	37
5.4	Switching Characteristics	37
5.4.1	Command Sequence Timing	37
5.4.2	Serial Audio Port	41
5.4.3	Serial Control Port—I ² C Operation	44
6	Application Information	45
6.1	Serial Audio Interface Clock Master and Slave Interface Configuration	46
6.1.1	Slave Configuration	46
6.1.2	Master Configuration	46
7	Mechanical Data	47
	Appendix A—Volume Table	49

List of Illustrations

<i>Figure</i>	<i>Title</i>	<i>Page</i>
2-1	Crystal Circuit	8
2-2	External PLL Loop Filter	10
2-3	I2S 64-Fs Format	11
2-4	I2S 48-Fs Format	12
2-5	Left-Justified 64-Fs Format	12
2-6	Left-Justified 48-Fs Format	13
2-7	Right-Justified 64-Fs Format	13
2-8	Right-Justified 48-Fs Format	14
2-9	DSP Format	14
2-10	Attenuation Curve	18
2-11	De-Emphasis Filter Characteristics	20
2-12	PWM Outputs and H-Bridge Driven in BTL Configuration	22
2-13	Typical I ² C Sequence	23
2-14	Single Byte Write Transfer	23
2-15	Multiple Byte Write Transfer	24
2-16	Single Byte Read	24

2-17 Multiple Byte Read	24
4-1 $\overline{\text{RESET}}$ During System Initialization	30
4-2 Extending the I ² C Write Interval Following a Low-to-High Transition of the $\overline{\text{RESET}}$ Terminal	31
4-3 Changing the Data Sample Rate Using the DBSPD Terminal	32
4-4 Changing the Data Sample Rate Using the I ² C	32
4-5 Changing the Data Sample Rate With An Unstable MCLK_IN Using the DBSPD Terminal	33
4-6 Changing the Data Sample Rate With An Unstable MCLK_IN Using the I ² C	34
4-7 Changing Between Master and Slave Clock Mode	35
5-1 $\overline{\text{RESET}}$ Timing	37
5-2 Power-Down and Power-Up Timing— $\overline{\text{RESET}}$ Preceding $\overline{\text{PDN}}$	38
5-3 Power-Down and Power-Up Timing— $\overline{\text{RESET}}$ Following $\overline{\text{PDN}}$	39
5-4 Error Recovery Timing	40
5-5 Mute Timing	40
5-6 Right-Justified, IIS, Left-Justified Serial Protocol Timing	41
5-7 Right, Left, and IIS Serial Mode Timing Requirement	42
5-8 Serial Audio Ports Master Mode Timing	42
5-9 DSP Serial Port Timing	42
5-10 DSP Serial Port Expanded Timing	43
5-11 DSP Absolute Timing	43
5-12 SCL and SDA Timing	44
5-13 Start and Stop Conditions Timing	44
6-1 Typical TAS5036B Application	45
6-2 TAS5036B Serial Audio Port—Slave Mode Connection Diagram	46
6-3 TAS5036B Serial Audio Port—Master Mode Connection Diagram	46

List of Tables

<i>Table</i>	<i>Title</i>	<i>Page</i>
2-1	Normal-Speed, Double-Speed, and Quad-Speed Operation	7
2-2	Master and Slave Clock Modes	9
2-3	LRCLK, MCLK_IN, and External PLL Rates	9
2-4	DCLK	10
2-5	Supported Word Lengths	11
2-6	Device Outputs During Reset	15
2-7	Values Set During Reset	15
2-8	Device Outputs During Power Down	16
2-9	Volume Register	19
2-10	De-Emphasis Filter Characteristics	19
2-11	Device Outputs During Error Recovery	21
3-1	I ² C Register Map	25
3-2	General Status Register (Read Only)	26
3-3	Error Status Register	26
3-4	System Control Register 0	26
3-5	System Control Register 1	27
3-6	Error Recovery Register	27

List of Tables

3-7 Automute Delay Register	28
3-8 DC-Offset Control Registers	28
3-9 Six Interchannel Delay Registers	28
3-10 ABD Delay Register	28
3-11 Individual Channel Mute Register	29

1 Introduction

The TAS5036B is an innovative, cost-effective, high-performance 24-bit six-channel digital pulse width modulator (PWM) based on Equibit™ technology. Combined with a TI digital amplifier power stage, these devices use noise-shaping and sophisticated error correction algorithms to achieve high power efficiency and high-performance digital audio reproduction. The TAS5036B is designed to drive up to six digital power devices to provide six channels of digital audio amplification. The digital power devices can be six conventional monolithic power stages (such as the TAS5110) or six discrete differential power stages using gate drivers and MOSFETs.

The TAS5036B has six independent volume controls and mute. The device operates in AD and BD modes. This all-digital audio system contains only two analog components in the signal chain—an LC low-pass filter at each speaker terminal and can provide up to 96-dB SNR at the speaker terminals. The TAS5036B has a wide variety of serial input options including right justified (16, 20, or 24 bit), I2S (16, 20, or 24 bit) left justified, or DSP (16 bit) data formats. The device is fully compatible with AES standard sampling rates of 44.1 kHz, 48 kHz, 88.2 kHz, 96 kHz, 176.4 kHz, and 192 kHz including de-emphasis for 44.1-kHz and 48-kHz sample rates. The TAS5036B plus the TAS51xx power stage device combination was designed for home theater applications such as DVD minicomponent systems, home theater in a box (HTIB), DVD receiver, A/V receiver, or TV sets.

1.1 Features

- True Digital Audio Amplifier
- High Quality Audio
 - 100-dB SNR
 - <0.005% THD+N
- Six-Channel Volume Control
 - Patented Soft Volume
 - Patented Soft Mute
- 16-, 20-, or 24-Bit Input Data
- Sampling Rates: 44.1 kHz, 48 kHz, 88.2 kHz, 96 kHz, 176.4 kHz, and 192 kHz
- Supports Master and Slave Modes
- 3.3-V Power Supply Operation
- Economical 80-Pin TQFP Package
- De-Emphasis: 32 kHz, 44.1 kHz, and 48 kHz
- Clock Oscillator Circuit for Master Modes
- Low Jitter Internal PLL
- Soft Volume and Mute Update

1.2 Functional Block Diagram

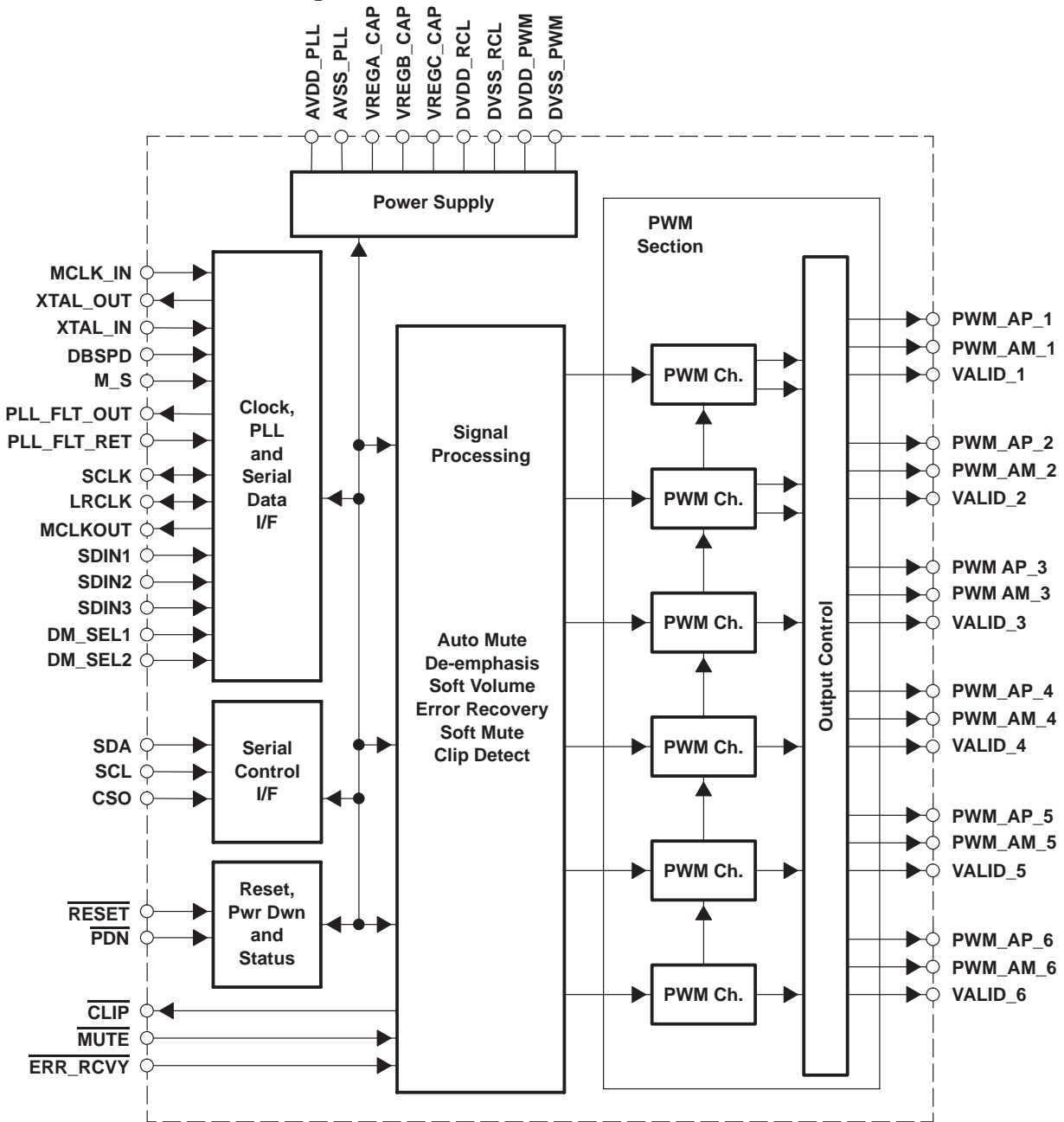

1.3 Terminal Assignments

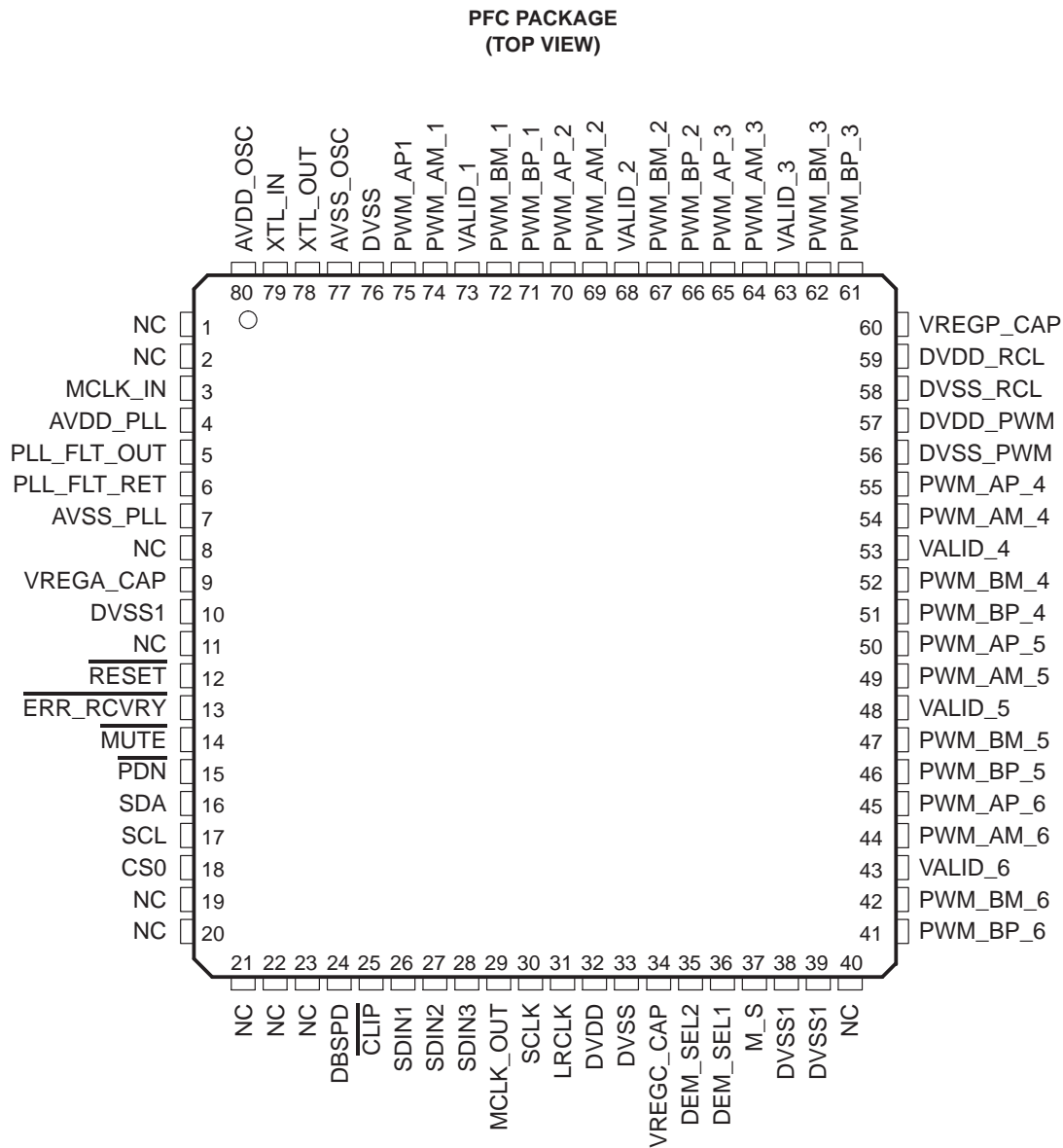

NC – No internal connection

1.4 Ordering Information

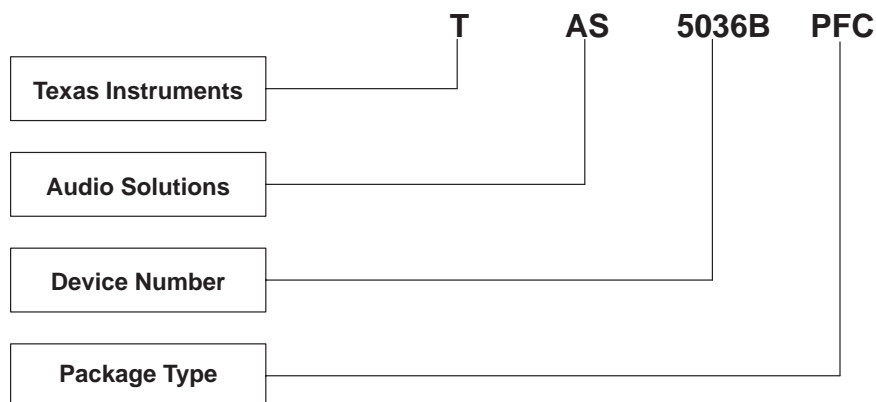

AVAILABLE OPTIONS

T _A	PACKAGE
	0°C to 70°C

1.5 Terminal Functions

TERMINAL NAME	NO.	I/O	DESCRIPTION
AVDD_OSC	80	P	Analog power supply for internal oscillator cells
AVDD_PLL	4	P	Analog power supply for PLL
AVSS_OSC	77	AO	Analog ground for internal oscillator cells
AVSS_PLL	7	P	Analog ground for PLL
CLIP	25	DO	Digital clipping indicator, active low
CS0	18	DI	I ² C serial control chip address select input, active high
DBSPD	24	DI	Sample rate is double speed (88.2 kHz or 96 kHz), active high
DM_SEL1	36	DI	De-emphasis select bit 2, 10 = 48 kHz, 11 = undefined (none)
DM_SEL2	35	DI	De-emphasis select bit 1 (0 = none, 01 = 32 kHz, 10 = 44.1 kHz)
DVDD	32	P	Digital power supply
DVDD_PWM	57	P	Digital power supply for PWM
DVDD_RCL	59	P	Digital power supply for reclocker
DVSS	33, 76	P	Digital ground for digital core and most of I/O buffers
DVSS1	10, 38, 39	DIO	Digital ground for digital core and most of I/O buffers
DVSS_PWM	56	P	Digital ground for PWM
DVSS_RCL	58	P	Digital ground for reclocker
ERR_RCVRY	13	DI	Error recovery input, active low
LRCLK	31	DIO	Serial audio data left / right clock (sampling rate clock) (input when M_S = 0; output when M_S = 1)
M_S	37	DI	Master/slave mode input signal (master = 1, slave = 0)
MCLK_IN	3	DI	MCLK input, slave mode (or master / double-speed mode)
MCLK_OUT	29	DO	MCLK output buffered system clock output if M_S = 1; otherwise set to 0
MUTE	14	DI	Mute input signal, active low (muted signal = 0, normal mode = 1)
N/C	1, 2, 8, 11, 19–23, 40		Not connected
PDN	15	DI	Power down, active low
PLL_FLT_OUT	5	AO	PLL external filter
PLL_FLT_RET	6	AO	PLL external filter (internally connected to AVSS_PLL)
PWM_AM_1	74	DO	PWM 1 output (differential -); {positive H-bridge side}

TERMINAL		I/O	DESCRIPTION
NAME	NO.		
PWM_AM_2	69	DO	PWM 2 output (differential -); {positive H-bridge side}
PWM_AM_3	64	DO	PWM 3 output (differential -); {positive H-bridge side}
PWM_AM_4	54	DO	PWM 4 output (differential -); {positive H-bridge side}
PWM_AM_5	49	DO	PWM 5 output (differential -); {positive H-bridge side}
PWM_AM_6	44	DO	PWM 6 output (differential -); {positive H-bridge side}
PWM_AP_1	75	DO	PWM 1 output (differential +); {positive H-bridge side}
PWM_AP_2	70	DO	PWM 2 output (differential +); {positive H-bridge side}
PWM_AP_3	65	DO	PWM 3 output (differential +); {positive H-bridge side}
PWM_AP_4	55	DO	PWM 4 output (differential +); {positive H-bridge side}
PWM_AP_5	50	DO	PWM 5 output (differential +); {positive H-bridge side}
PWM_AP_6	45	DO	PWM 6 output (differential +); {positive H-bridge side}
PWM_BM_1	72	DO	PWM 1 output (differential -); {negative H-bridge side}
PWM_BM_2	67	DO	PWM 2 output (differential -); {negative H-bridge side}
PWM_BM_3	62	DO	PWM 3 output (differential -); {negative H-bridge side}
PWM_BM_4	52	DO	PWM 4 output (differential -); {negative H-bridge side}
PWM_BM_5	47	DO	PWM 5 output (differential -); {negative H-bridge side}
PWM_BM_6	42	DO	PWM 6 output (differential -); {negative H-bridge side}
PWM_BP_1	71	DO	PWM 1 output (differential +); {negative H-bridge side}
PWM_BP_2	66	DO	PWM 2 output (differential +); {negative H-bridge side}
PWM_BP_3	61	DO	PWM 3 output (differential +); {negative H-bridge side}
PWM_BP_4	51	DO	PWM 4 output (differential +); {negative H-bridge side}
PWM_BP_5	46	DO	PWM 5 output (differential +); {negative H-bridge side}
PWM_BP_6	41	DO	PWM 6 output (differential +); {negative H-bridge side}
RESET	12	DI	System reset input, active low
SCL	17	DI	I ² C serial control clock input
SCLK	30	DIO	Serial audio data clock (shift clock)
SDA	16	DIO	I ² C serial control data input/ output
SDIN1	26	DI	Serial audio data 1 input
SDIN2	27	DI	Serial audio data 2 input
SDIN3	28	DI	Serial audio data 3 input
VALID_1	73	DO	Output indicating validity of PWM outputs, channel 1, active high
VALID_2	68	DO	Output indicating validity of PWM outputs, channel 2, active high
VALID_3	63	DO	Output indicating validity of PWM outputs, channel 3, active high
VALID_4	53	DO	Output indicating validity of PWM outputs, channel 4, active high
VALID_5	48	DO	Output indicating validity of PWM outputs, channel 5, active high
VALID_6	43	DO	Output indicating validity of PWM outputs, channel 6, active high
VREGA_CAP	9	P	Voltage regulator capacitor
VREGB_CAP	60	P	Voltage regulator capacitor
VREGC_CAP	34	P	Voltage regulator capacitor
XTL_IN	79	AI	Crystal or TTL level clock input
XTL_OUT	78	AO	Crystal output (not for external usage)

2 Architecture Overview

The TAS5036B is composed of six functional elements:

- Clock, PLL, and serial data interface (IIS)
- Reset/power-down circuitry
- Serial control interface (IIC)
- Signal processing unit
- Pulse width modulator (PWM)
- Power supply

2.1 Clock and Serial Data Interface

The TAS5036B clock and serial data interface contain an input serial data slave and the clock master/ slave interface. The serial data slave interface receives information from a digital source such as a DSP, S/PDIF receiver, analog-to-digital converter (ADC), digital audio processor (DAP), or other serial bus master. The serial data interface has three serial data inputs that can accept up to six channels of data at data sample rates of 32 kHz, 44.1 kHz, 48 kHz, 88.2 kHz, 96 kHz, 176.4 kHz, and 192 kHz. The serial data interfaces support left justified and right justified for 16-, 20-, and 24-bits. In addition, the serial data interface supports the DSP protocol for 16 bits and the I2S protocol for 24 bits.

The TAS5036B can function as a receiver or a generator for the MCLK_IN (master clock), SCLK (shift clock), and LRCLK (left/right clock) signals that control the flow of data on the three serial data interfaces. The TAS5036B is a clock master when it generates these clocks and is a clock slave when it receives these clocks.

The TAS5036B is a synchronous design that relies upon the master clock to provide a reference clock for all of the device operations and communication via the I²C. When operating as a slave, this reference clock is MCLK_IN. When operating as a master, the reference clock is either a TTL clock input to XTAL_IN or a crystal attached across XTAL_IN and XTAL_OUT.

The clock and serial data interface has two control parameters: data sample rate and clock master or slave.

2.1.1 Normal-Speed, Double-Speed, and Quad-Speed Selection

The data sample rate is selected through a terminal (DBSPD) or the serial control register 0 (X02). The data sample rate control sets the frequencies of the SCLK and LRCLK in clock slave mode and the output frequencies of SCLK and LRCLK in clock master mode. There are three data rates: normal speed, double speed, and quad speed.

Normal-speed mode supports data rates of 32 kHz, 44.1 kHz, and 48 kHz. Normal speed is supported in the master and slave modes. Double-speed mode is used to support sampling rates of 88.2 kHz and 96 kHz. Double speed is supported in master and slave modes. Quad-speed mode is used to support sampling rates of 176.4 kHz and 192 kHz.

The PWM is placed in normal speed by setting the DBSPD terminal low or by setting the normal mode bits in the system control register 0 (x02) through the serial control interface. The PWM is placed in double speed mode by setting the DBSPD terminal high or by setting the double speed bits in the system control register. Quad-speed mode is auto detected supported in slave mode and invoked using the I²C serial control interface in master mode. In slave mode, if the TAS5036B is not in double speed mode, quad-speed mode is automatically detected when MCLK_IN is 128Fs. In master mode, the PWM is placed in quad-speed mode by setting the quad-speed bit in the system control register through the serial control interface.

If the master clock is well behaved during the frequency transition (the high or low clock periods are not less than 20 ns) then a simple speed selection is simply performed by setting the DBSPD terminal or the serial control register.

When the sample rate is changed, the TAS5036B temporarily suspends processing, places the PWM outputs in a hard mute (PWM P outputs low; PWM M outputs high and all VALID signals low), resets all internal processes, and suspends all I²C operations. The TAS5036B then performs a partial re-initialization and noiselessly restarts the PWM output. The TAS5036B preserves all control register settings throughout this sequence. If desired, the sample rate change can be performed while mute is active to provide a completely silent transition. The timing of this control sequence is shown in Section 4.

If the master clock input can encounter high clock or low clock period of less than 20 ns while the data rates are changing, then **RESET** should be applied during this time. There are two recommended control procedures for this case, depending upon whether the DBSPD terminal or the serial control interface is used. These control sequences are shown in Section 4.

Table 2–1. Normal-Speed, Double-Speed, and Quad-Speed Operation

QUAD-SPEED CONTROL REGISTER BIT	DBSPD TERMINAL OR CONTROL REGISTER BIT	MODE	SPEED SELECTION
0	0	Master or slave	Normal speed
0	1	Master or slave	Double speed
1	0	Master or slave	Quad speed
0	0	Slave	Quad speed if MCLK_IN = 128Fs
1	1	Master or slave	Error

2.1.2 Clock Master/Slave Mode (M_S)

Clock master and slave mode can be invoked using the M_S (master slave) terminal.

This terminal specifies the default mode that is set immediately following a device RESET. The serial data interface setting permits the clock generation mode to be changed during normal operation.

The transition to master mode occurs:

- Following a RESET when M_S terminal has a logic high applied

The transition to slave mode occurs:

- Following a RESET when M_S terminal has a logic low applied

2.1.3 Clock Master Mode

When M_S = 1 following a RESET, the TAS5036B provides the master clock, SCLK, and LRCLK to the rest of the system. In the master mode, the TAS5036B outputs the audio system clocks MCLK_OUT, SCLK, and LRCLK.

The TAS5036B device generates these clocks plus its internal clocks from the internal phase-locked loop (PLL). The reference clock for the PLL can be provided by either an external clock source (attached to XTAL_IN) or a crystal (connected across terminals XTAL_IN and XTAL_OUT). The external source attached to MCLK_IN is 256 times (128 in quad mode) the data sample rate (Fs). The SCLK frequency is 64 times the data sample rate and the SCLK frequency of 48 times the data sample rate is not supported in the master mode. The LRCLK frequency is the data sample rate.

2.1.3.1 Crystal Type and Circuit

In clock master mode the TAS5036B can derive the MCLKOUT, SCLK, and LRCLK from a crystal. In this case, the TAS5036B uses a parallel-mode fundamental-mode crystal. This crystal is connected to the TAS5036B as shown in Figure 2–1.

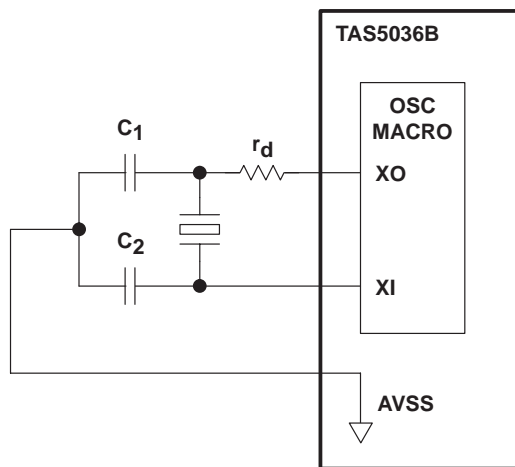

r_d = Drive level control resistor – crystal vendor specified
 C_L = Crystal load capacitance (capacitance of circuitry between the two terminals of the crystal)
 $C_L = (C_1 \times C_2) / (C_1 + C_2) + C_S$ (where C_S = board stray capacitance ~ 3 pF)
 Example: Vendor recommended $C_L = 18$ pF, $C_S = 3$ pF $\geq C_1 = C_2 = 2 \times (18-3) = 30$ pF

Figure 2–1. Crystal Circuit

2.1.4 Clock Slave Mode

In the slave mode ($M_S = 0$), the master clock, LRCLK, and SCLK are inputs to the TAS5036B. The master clock is supplied through the MCLK_IN terminal.

As in the master mode, the TAS5036B device develops its internal timing from the internal phase-locked loop (PLL). The reference clock for the PLL is provided by the input to the MCLK_IN terminal. This input is at a frequency of 256 times (128 in quad mode) the input data rate. The SCLK frequency is 48 or 64 times the data sample rate. The LRCLK frequency is the data sample rate. The TAS5036B does not require any specific phase relationship between SRCLK and MCLK_IN, but there must be synchronization. The TAS5036B monitors the relationship between MCLK, SCLK, and LRCLK. The TAS5036B detects if any of the three clocks are absent, if the LRCLK rate changes more than 10 MCLK cycles since the last device reset or clock error, or if the MCLK frequency is changing substantially with respect to the PLL frequency.

When a clock error is detected, the TAS5036B performs a clock error management sequence.

The clock error management sequence temporarily suspends processing, places the PWM outputs in a hard mute (PWM_P outputs are low; PWM_M outputs are high, and all VALID signals are low), resets all internal processes, sets the volumes to mute, and suspends all I²C operations.

When the error condition is corrected, the TAS5036B exits the clock error sequence by performing a partial re-initialization, noiselessly restarting the PWM output, and ramping the volume up to the level specified in the volume control registers. This sequence is performed over a 60 ms. interval. The TAS5036B preserves all control register settings that were set prior to the clock interruption.

If a clock error occurs while the ERR_RCVRY terminal is asserted (low), the TAS5036B performs the error management sequence up to the unmute sequence. In this case, the volume remains at full attenuation with the PWM output at a 50% duty cycle. The volume can be restored from this latched mute state by triggering a mute/unmute sequence by asserting and releasing \overline{MUTE} either by using the terminal, the system control register X01 D4, or the individual channel mute register D5–D0.

Alternatively, the TAS5036B can be prevented from entering the latched mute state following a clock error when the `ERR_RCVRY` terminal or the error recovery I²C command (register X03 bit D2) is active by writing x7F to the individual error recovery register (x04) and a x84 to x1F (a feature enable register).

Table 2–2. Master and Slave Clock Modes

DESCRIPTION	M_S	DBSPD	XTL_IN (MHz) [†]	MCLK_IN (MHz) [‡]	SCLK (MHz) [¶]	LRCLK (kHz) [¶]	MCLK_OUT (MHz) [#]
Internal PLL, master, normal speed	1	0	8.192	-	2.048	32	8.192
Internal PLL, master, normal speed	1	0	11.2896	-	2.8224	44.1	11.2896
Internal PLL, master, normal speed	1	0	12.288	-	3.072	48	12.288
Internal PLL, master, double speed	1	1	-	22.5792 [§]	5.6448	88.2	22.5792
Internal PLL, master, double speed	1	1	-	24.576 [§]	6.144	96	24.576
Internal PLL, master, quad speed	1	0	-	22.5792	11.2896	176.4	22.5792
Internal PLL, master, quad speed	1	0	-	24.576	12.288	192	24.576
Internal PLL, slave, normal speed	0	0	-	8.192 [§]	2.0484	32	Digital GND
Internal PLL, slave, normal speed	0	0	-	11.2896 [§]	2.8224	44.1	Digital GND
Internal PLL, slave, normal speed	0	0	-	12.288 [§]	3.072	48	Digital GND
Internal PLL, slave, double speed	0	1	-	22.5792	5.6448	88.2	Digital GND
Internal PLL, slave, double speed	0	1	-	24.576 [§]	6.144	96	Digital GND
Internal PLL, slave, quad speed	0	0	-	22.5792 [§]	11.2896	176	Digital GND
Internal PLL, slave, quad speed	0	0	-	24.576 [§]	12.288	192	Digital GND
External PLL, master, normal speed	1	0	-	-	2.048	32	8.192
External PLL, master, normal speed	1	0	-	-	2.8224	44.1	11.2896
External PLL, master, normal speed	1	0	-	-	3.072	48	12.288
External PLL, master, double speed	1	1	-	-	5.6448	88.2	22.5792
External PLL, master, double speed	1	1	-	-	6.144	96	24.576
External PLL, master, quad speed	1	0	-	-	11.2896	176.4	22.5792
External PLL, master, quad speed	1	0	-	-	12.288	192	24.576
External PLL, slave, normal speed	0	0	-	8.192 [§]	2.0484	32	Digital GND
External PLL, slave, normal speed	0	0	-	11.2896 [§]	2.8224	44.1	Digital GND
External PLL, slave, normal speed	0	0	-	12.288 [§]	3.072	48	Digital GND
External PLL, slave, double speed	0	1	-	22.5792	5.6448	88.2	Digital GND
External PLL, slave, double speed	0	1	-	24.576 [§]	6.144	96	Digital GND
External PLL, slave, quad speed	0	0	-	22.5792 [§]	11.2896	176	Digital GND
External PLL, slave, quad speed	0	0	-	24.576 [§]	12.288	192	Digital GND

[†] A crystal oscillator is connected to XTL_IN.

[‡] MCLK_IN tied low when input to XTL_IN is provided; XTL_IN tied low when MCLK_IN_IN is provided.

[§] External MCLK_IN connected to MCLK_IN_IN input

[¶] SCLK and LRCLK are outputs when M_S=1, and inputs when M_S=0.

[#] MCLK_OUT is driven low when M_S=0.

^{||} Quad-speed mode is detected automatically.

☆ SCLK can be 48 or 64 times Fs

Table 2–3. LRCLK, MCLK_IN, and External PLL Rates

LRCLK	NORMAL SPEED (kHz)				DOUBLE SPEED (kHz)				QUAD SPEED (kHz)		
	1FS	32	44.1	48	1FS	64	88.2	96	1FS	176.4	192
MCLK_IN	256FS	8,192	11,289.6	12,288	256FS	16,384	22,579.2	24,576	128FS	22,579.2	24,576
EXT. PLL	2048FS	65,536	90,316.8	98,304	1024FS	65,536	90,316.8	98,304	512FS	90,316.8	98,304

2.1.5 PLL Filter

A low jitter PLL produces the internal timing of the TAS5036B (when in master mode), the master clock, SCLK, and LRCLK. Connections for the PLL external loop filter are provided through PLL_FLT_OUT and PLL_FLT_RET as shown in Figure 2–2.

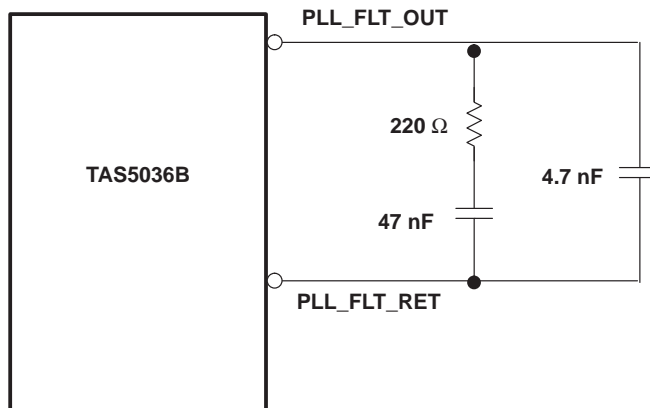

Figure 2–2. External PLL Loop Filter

2.1.6 DCLK

DCLK is the internal high frequency clock that is produced by the PLL circuitry from MCLK. The TAS5036B uses the DCLK to control all internal operations. DCLK is 8 times the speed of MCLK in normal speed mode, 4 times MCLK in double speed, and 2 times MCLK in quad speed. With respect to the I²C addressable registers, DCLK clock cycles are used to specify interchannel delay and to detect when the MCLK frequency is drifting. Table 2–4 DCLK shows the relationship between Sample Rate, MCLK, and DCLK.

Table 2–4. DCLK

FS (kHz)	MCLK (MHz)	DCLK (MHz)	DCK Period (ns)
32	8.1920	65.5360	15.3
44.1	11.2896	90.3168	11.1
48	12.2880	98.3040	10.2
88	22.5280	90.1120	11.1
96	24.5760	98.3040	10.2
192	49.1520	98.3040	10.2

2.1.7 Serial Data Interface

The TAS5036B operates as a slave only/receive only serial data interface in all modes. The TAS5036B has three PCM serial data interfaces to accept six channels of digital data through the SDIN1, SDIN2, SDIN3 inputs. The serial audio data is in MSB first; 2s complement format.

The serial data interfaces of the TAS5036B can be configured in right justified, I²S, left-justified, or DSP modes. This interface supports 32-kHz, 44.1-kHz, 48-kHz, 88-kHz, 96-kHz, 176.4-kHz, and 192-kHz data sample rates. The serial data interface format is specified using the data interface control register. The supported word lengths are shown in Table 2–5.

During normal operating conditions if the serial data interface settings change state, an error recovery sequence is initiated.

Table 2–5. Supported Word Lengths

DATA MODES	WORD LENGTHS	MOD2	MOD1	MOD0
Right justified, MSB first	16	0	0	0
Right justified, MSB first	20	0	0	1
Right justified, MSB first	24	0	1	0
I ² S	16	0	1	1
I ² S	20	1	0	0
I ² S	24	1	0	1
Left justified, MSB first	24	1	1	0
DSP frame	16	1	1	1

2.1.7.1 I²S Timing

I²S timing uses an LRCLK to define when the data being transmitted is for the left channel or the right channel. The LRCLK is low for the left channel and high for the right channel. A bit clock running at 48 or 64 times F_s is used to clock in the data. There is a delay of one bit clock from the time the LRCLK signal changes state to the first bit of data on the data lines. The data is written MSB first and is valid on the rising edge of the bit clock. The TAS5036B masks unused trailing data bit positions. Master mode only supports a 64 times F_s bit clock.

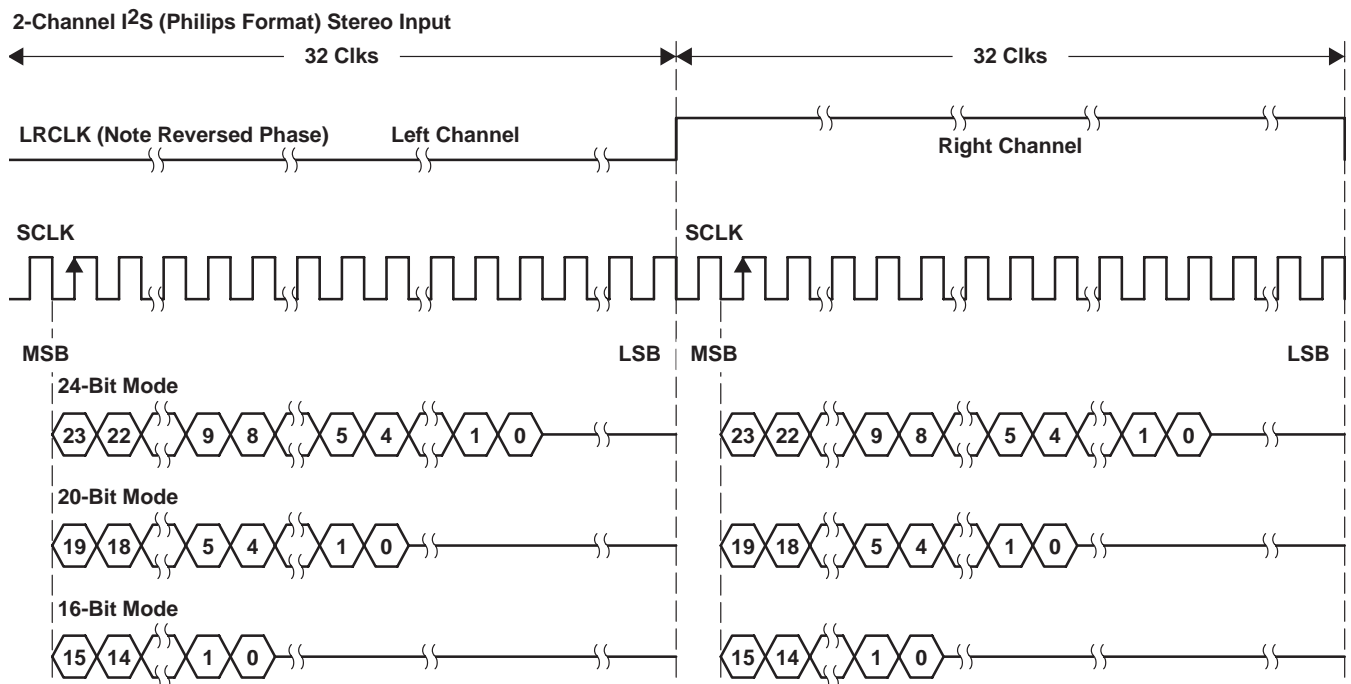
Figure 2–3. I²S 64- F_s Format

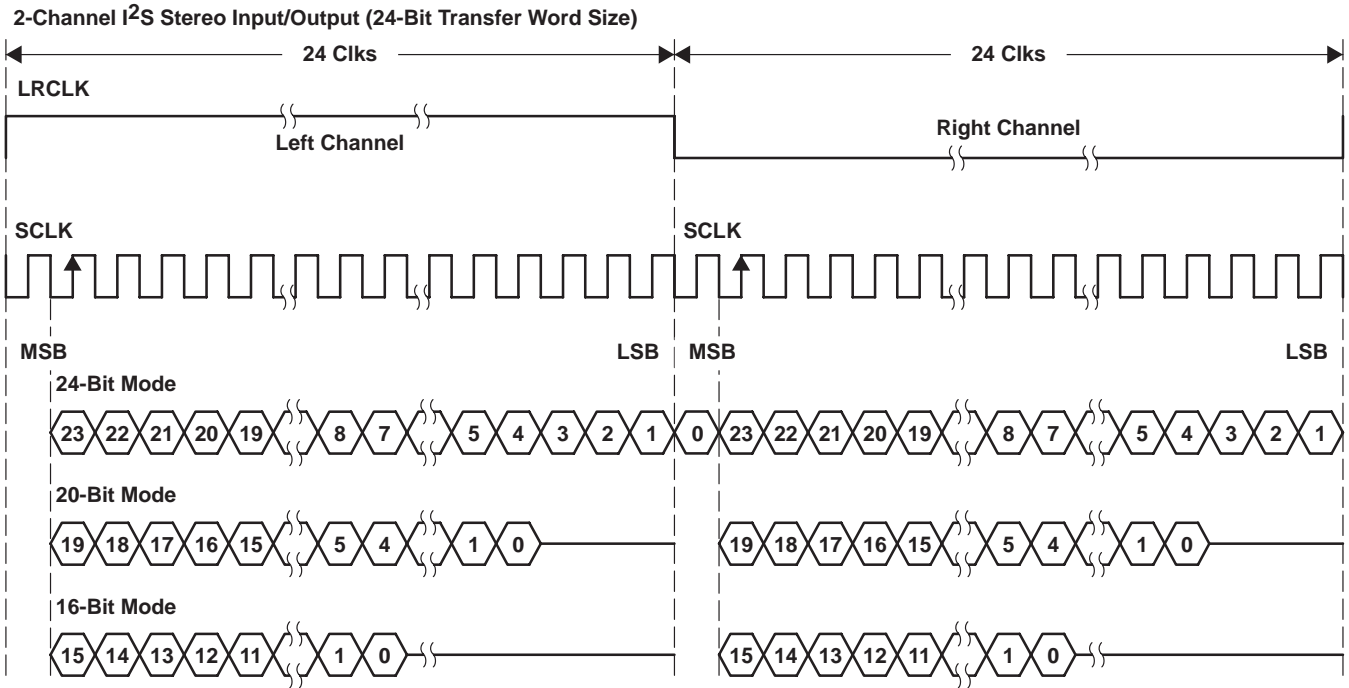
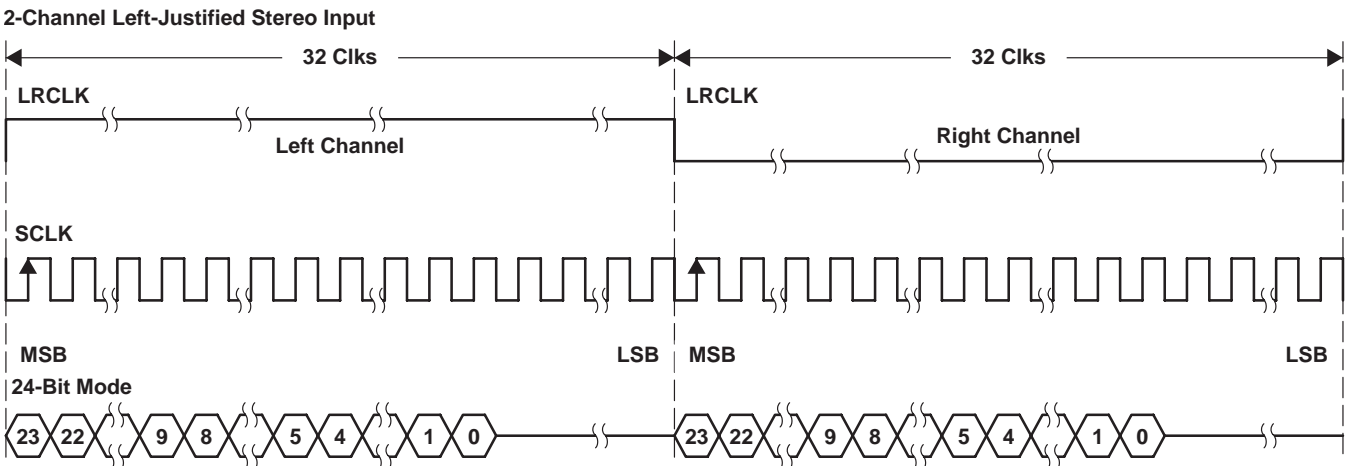

Figure 2–4. I²S 48-Fs Format

2.1.7.2 Left-Justified Timing

Left-justified (LJ) timing uses an LRCLK to define when the data being transmitted is for the left channel and the right channel. The LRCLK is high for the left channel and low for the right channel. A bit clock running at 48 or 64 times F_s is used to clock in the data. The first bit of data appears on the data lines at the same time the LRCLK toggles. The data is written MSB first and is valid on the rising edge of the bit clock. The TAS5036B masks unused trailing data bit positions. Master mode only supports a 64 times F_s bit clock.



NOTE: All data presented in 2s complement form with MSB first.

Figure 2–5. Left-Justified 64-Fs Format

2-Channel Left-Justified Stereo Input/Output (24-Bit Transfer Word Size)

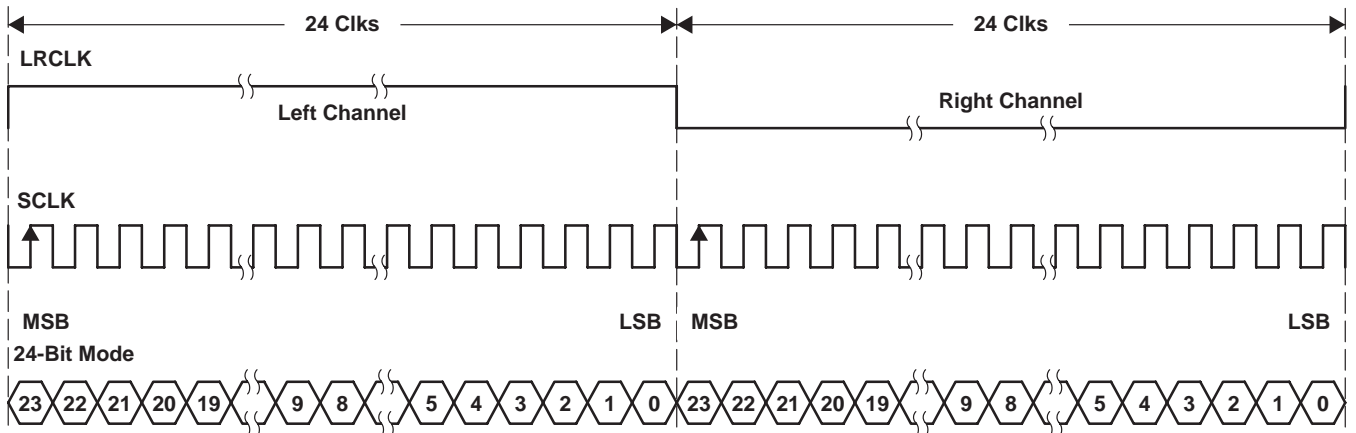
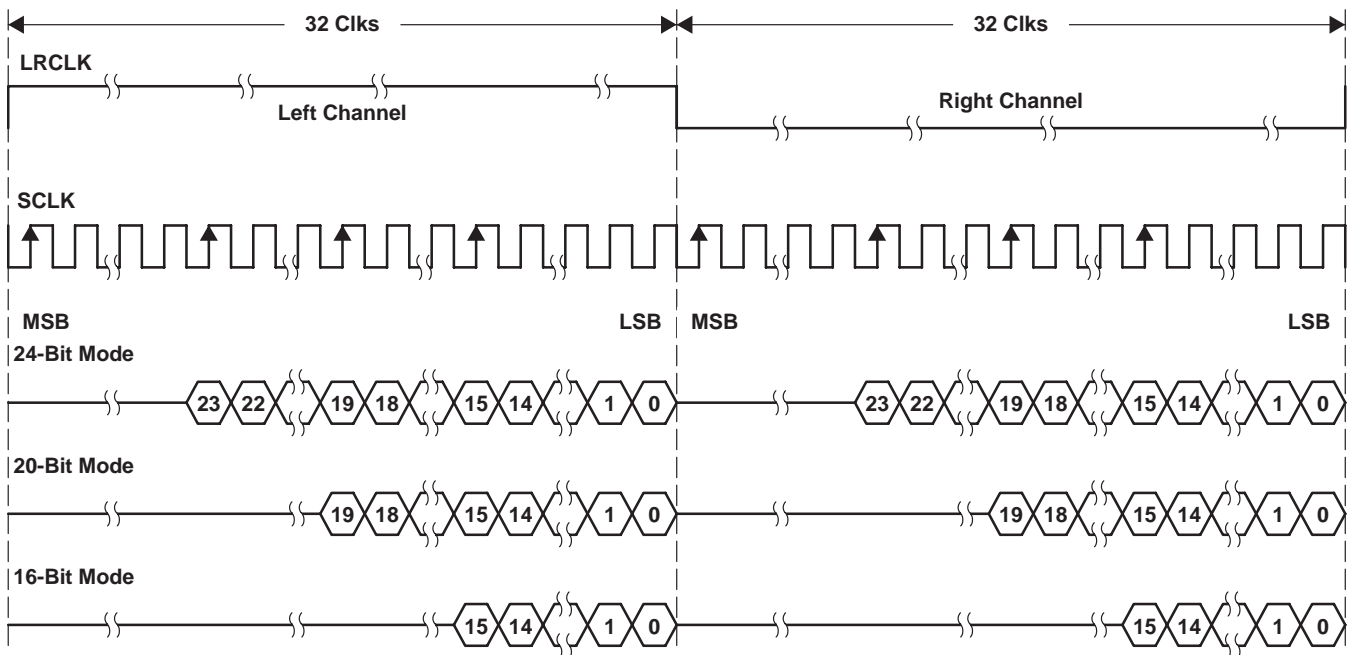

Figure 2–6. Left-Justified 48-Fs Format

2.1.7.3 Right-Justified Timing

Right-justified (RJ) timing uses an LRCLK to define when the data being transmitted is for the left channel and the right channel. The LRCLK is high for the left channel and low for the right channel. A bit clock running at 48 or 64 times F_s is used to clock in the data. The first bit of data appears on the data 8-bit clock periods (for 24-bit data) after LRCLK toggles. In RJ mode, the last bit clock before LRCLK transitions always clocks the LSB of data. The data is written MSB first and is valid on the rising edge of the bit clock. The TAS5036B masks unused leading data bit positions. Master mode only supports a 64 times F_s bit clock.

2-Channel Right-Justified (Sony Format) Stereo Input



NOTE: All data presented in 2s complement form with MSB first.

Figure 2–7. Right-Justified 64-Fs Format

2-Channel Right-Justified Stereo Input/Output (24-Bit Transfer Word Size)

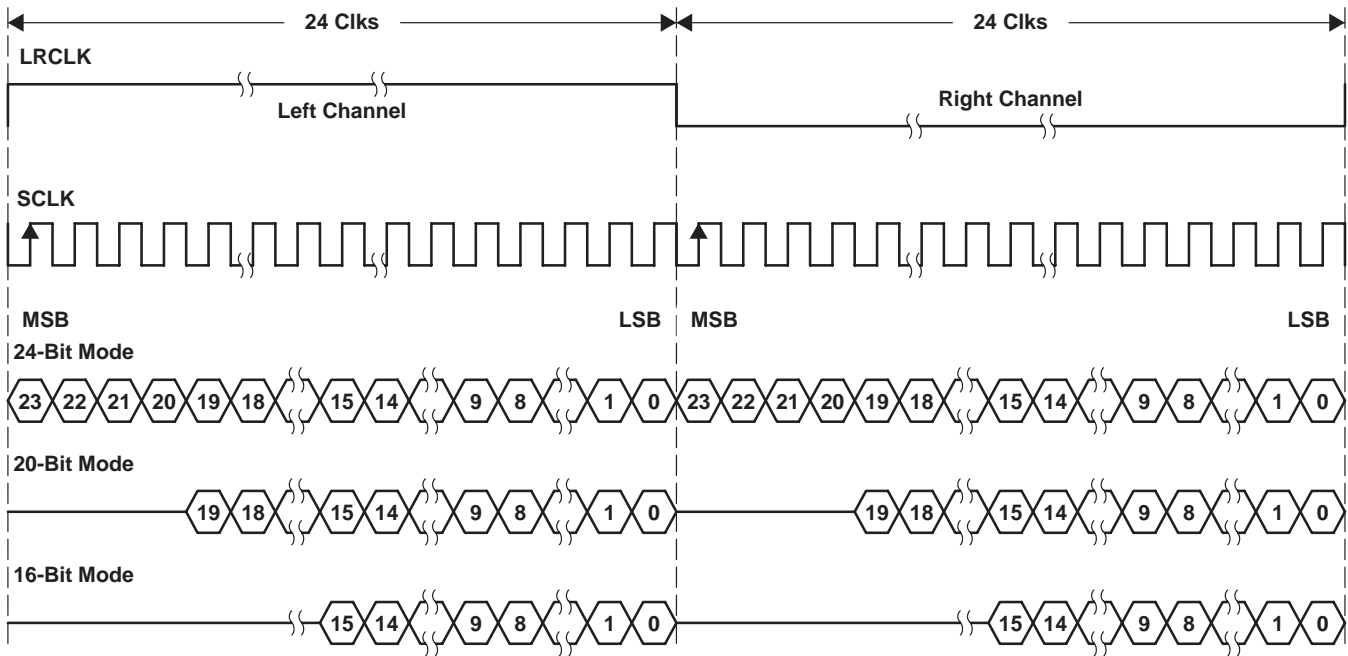

NOTE: All data presented in 2s complement form with MSB first.

Figure 2–8. Right-Justified 48-Fs Format

2.1.7.4 DSP Mode Timing

DSP mode timing uses an LRCLK to define when data is to be transmitted for both channels. A bit clock running at $64 \times F_s$ is used to clock in the data. The first bit of the left channel data appears on the data lines following the LRCLK transition. The data is written MSB first and is valid on the rising edge of the bit clock. The TAS5036B masks unused trailing data bit positions.

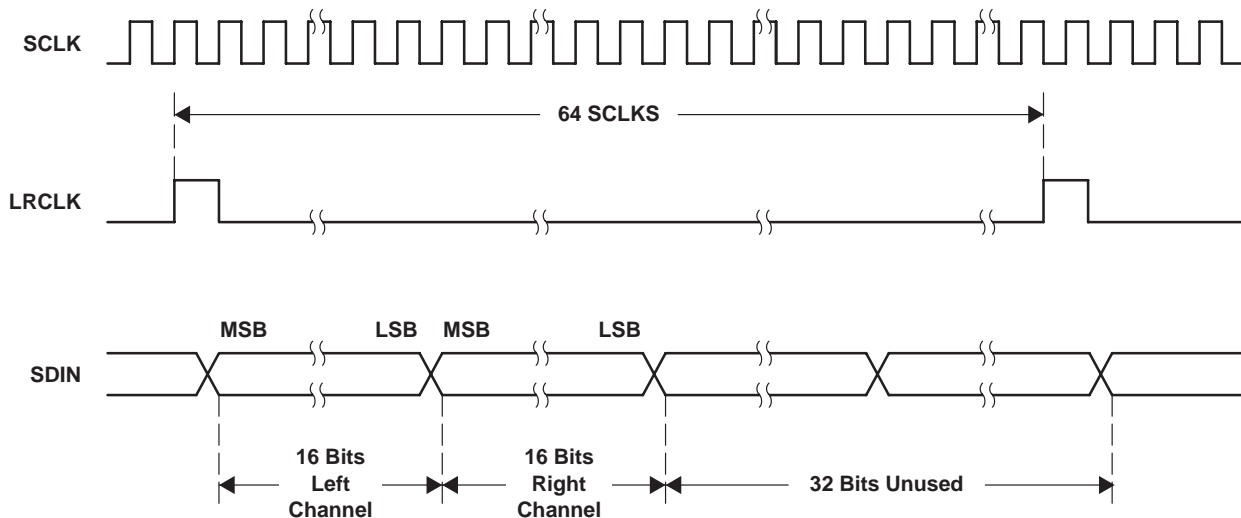

Figure 2–9. DSP Format

2.2 Reset, Power Down, and Status

The reset, power down, and status circuitry provides the necessary controls to bring the TAS5036B to the initial inactive condition, achieve low power standby, and report system status.

2.2.1 Reset— $\overline{\text{RESET}}$

The TAS5036B is placed in the reset mode by setting the $\overline{\text{RESET}}$ terminal low.

$\overline{\text{RESET}}$ is an asynchronous control signal that restores the TAS5036B to its default conditions, sets the valid 1–6 outputs low, and places the PWM in the hard mute state. Volume is immediately set to full attenuation (there is no ramp down).

As long as the $\overline{\text{RESET}}$ terminal is held low, the device is in the reset state. During reset, all I²C and serial data bus operations are ignored. Table 2–6 shows the device output signals while $\overline{\text{RESET}}$ is active.

Upon the release of $\overline{\text{RESET}}$, if POWER_DWN is high, the system performs a 4-ms to 5-ms device initialization and then ramps the volume up to 0 db using a soft volume update sequence. If MCLK_IN is not active when $\overline{\text{RESET}}$ is released high, then a 4-ms to 5-ms initialization sequence is produced once MCLK_IN becomes active.

During device initialization all controls are reset to their initial states. Table 2–7 shows the control settings that are changed during initialization.

$\overline{\text{RESET}}$ should be applied during power-up initialization or while changing the master slave clock states.

Table 2–6. Device Outputs During Reset

SIGNAL	MODE	SIGNAL STATE
Valid 1–Valid 6	All	Low
PWM P-outputs	All	Low
PWM M-outputs	All	Low
MCLKOUT	All	Low
SCLK	Master	Low
SCLK	Slave	Signal input
LRCLK	Master	Low
LRCLK	Slave	Signal input
SDA	All	Signal input
CLIP	All	High

Because the $\overline{\text{RESET}}$ is an asynchronous control signal, small clicks and pops can be produced during the application (the leading edge) of this control. However, when $\overline{\text{RESET}}$ is released, the transition from the hard mute state back to normal operation is performed synchronously using a quiet sequence.

If a completely quiet reset sequence is desired, $\overline{\text{MUTE}}$ should be applied before applying $\overline{\text{RESET}}$.

Table 2–7. Values Set During Reset

CONTROL	SETTING
Volume	0 dB
MCLK_IN frequency	256
Master/slave mode	M_S terminal state
Automute	Enabled
De-emphasis	None
DC offset	0
Interchannel delay	Each channel is set to default value

2.2.2 Power Down— $\overline{\text{PDN}}$

The TAS5036B can be placed into the power-down mode by holding the $\overline{\text{PDN}}$ terminal low. When power-down mode is entered, both the PLL and the oscillator are shut down. Volume is immediately set to full attenuation (there is no ramp down). The valid 1–6 outputs are immediately asserted low and the PWM outputs are placed in the hard mute state. $\overline{\text{PDN}}$ initiates device power down without clock inputs. As long as the $\overline{\text{PDN}}$ terminal is held low—the device is in the power-down (hard mute) state.

During power down, all I²C and serial data bus operations are ignored. Table 2–8 shows the device output signals while $\overline{\text{PDN}}$ is active.

Table 2–8. Device Outputs During Power Down

SIGNAL	MODE	SIGNAL STATE
Valid 1–Valid 6	All	Low
PWM P-outputs	All	Low
PWM M-outputs	All	Low
MCLKOUT	All	Low
SCLK	Master	Low
SCLK	Slave	Signal input
LRCLK	Master	Low
LRCLK	Slave	Signal input
SDA	All	Signal input
$\overline{\text{CLIP}}$	All	High

To place the device in total power-down mode, both RESET and power-down modes must be enabled. Prior to bringing $\overline{\text{PDN}}$ high, RESET must be brought low for a minimum of 50 ns.

Because $\overline{\text{PDN}}$ is an asynchronous control signal, small clicks and pops can be produced during the application (the leading edge) of this control. However, when $\overline{\text{PDN}}$ is released, the transition from the hard mute state back to normal operation is performed synchronously using a quiet sequence.

If a completely quiet reset sequence is desired, $\overline{\text{MUTE}}$ should be applied before applying $\overline{\text{PDN}}$.

2.2.3 General Status Register

The general status register is a read only register. This register provides an indication when a volume update is in progress or one of the channels is inactive. The device id can be read using this register.

Volume update is in progress—Whenever a volume change is in progress due to a volume update command or mute, this status bit is high.

Device identification code—The device identification code 1 0 0 1 1 is displayed.

No internal errors (all valid signals are high)—When there are no internal errors in the TAS5036B and all outputs are valid, this status bit is high.

One or more valid signals are inactive—If low, one or more channels of the TAS5036B are not outputting data. The valid signals for those channels are inactive.

This can be produced by one of three causes:

- One or more of the clock signals are in error
- $\overline{\text{ERROR}}$ recover is active (low)
- The automute has silenced one or more channels that are receiving 0 inputs
- $\overline{\text{MUTE}}$ has been set
- Volume control has been set to full attenuation

If this signal is high, the TAS5036B is outputting data on all channels.

2.2.4 Error Status Register

The error status register indicates historical information on control signal changes and clock errors. This register latches these indications when they occur. The indications are cleared by writing a 00(Hex) to the register.

This register is intended as a diagnostic tool to be used only when the system is not operating correctly. This is because the error status bits are set when the data rate, serial data interface format, or master/slave mode is changed. As a result, this register indicates an error condition even though the system is operating normally. This register should only be used while diagnosing transient error conditions.

Any clock error or control signal terminal change which occurs since the last time the error status register was cleared is displayed. In using this register, the first step is to initialize the device and verify that all of the clock signals are active. Then this register should be cleared by writing a 00(Hex). At this point, the register indicates any errors or control signal changes.

This register indicates an error condition by a high for the following conditions:

- FS ERROR
- A control terminal change has occurred ($\overline{M_S}$, DBLSPD)
- LRCLK error
- MCLK_IN count error
- DCLK phase error with respect to MCLK_IN
- MCLK_IN phase error with respect to DCLK
- PWM timing error

If all bits of the register are low, no errors have occurred and no control terminals changed.

There is no one-to-one correspondence of clock error indication to a system error condition. A particular system error can be indicated by one or more error indications in this register. The system error conditions and the reported errors are as follows:

There is no correct number of MCLKs per LRCLK:

- FS error has occurred or
- LRCLK error or
- MCLK_IN count error

LRCLK is absent:

- LRCLK error

MCLK is the wrong frequency, changing frequency, or absent:

- DCLK phase error with respect to MCLK
- MCLK phase error with respect to DCLK
- PWM timing error

SCLK is the wrong frequency or absent

- SCLK error

2.3 Signal Processing

This section contains the signal processing functions that are contained in the TAS5036B. The signal processing is performed using a high-speed 24-bit signal processing architecture. The TAS5036B performs the following signal processing features:

- Individual channel soft volume with a range of 24 dB to -114 dB plus mute
- Soft mute
- Automute
- 50- μ s/15- μ s de-emphasis filter supported in the sampling rates 32 kHz, 44.1 kHz, and 48 kHz

2.3.1 Volume Control

The gain of each output can be adjusted by a soft digital volume control for each channel. Volume adjustments are performed using a soft gain update s-curve, which is approximated using a second order filter fit. The curve fit is performed over a transition interval between 41 ms and 65 ms.

The volume of each channel can be adjusted from mute to 24 dB to -114 dB in 0.5 dB steps. Because of the numerical representation that is used to control the volume, at very low volume levels the step size increases for gains of that are less than -96 dB. The default volume setting following power up or reset is 0 dB for all channels. The step size increases linearly up to approximately -90 dB, see Figure 2-10.

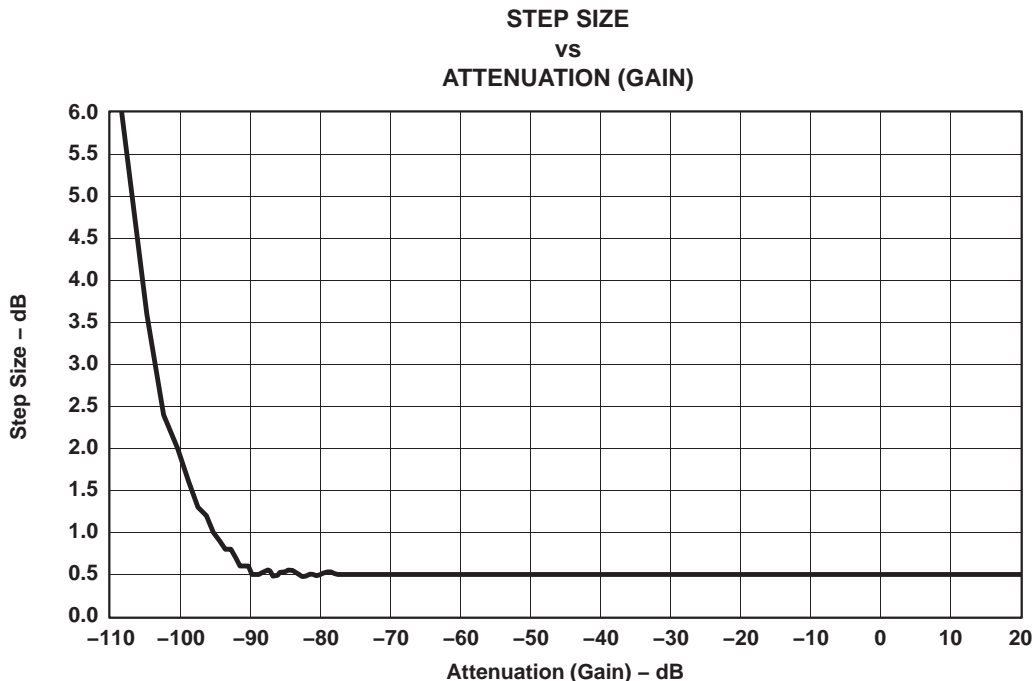

Figure 2-10. Attenuation Curve

The volume control format for each channel is expressed in 8 bits. The volume for each channel is set by writing 8 bits via the serial control interface. The MSB bit is written first as in the bit position 0 (LSB position).

The volume for each channel can be set using a single or multiple address write operation to the volume control register via the serial control interface. Changing the volume of all six channels requires that 6 registers be updated.

To coordinate the volume adjustment of multiple channels simultaneously, the TAS5036B performs a delayed volume update upon receiving a volume change command. Following the completion of the register volume write operations, the TAS5036B waits for 5 ms for another volume command to be given. If no volume command is issued in that period of time, the TAS5036B starts adjusting the volume of the channels that received volume settings.

While a volume update is being performed, the system status register indicates that the update is in progress. During the update, all subsequent volume control setting requests that are sent to the TAS5036B are received and stored as a single next value for a subsequent update. If more than one volume setting request is sent, only the last is retained.

Table 2–9. Volume Register

VOLUME REGISTER							
D 7	D 6	D 5	D 4	D 3	D 2	D 1	D 0
Vol Bit 7	Vol Bit 6	Vol Bit 5	Vol Bit 4	Vol Bit 3	Vol Bit 2	Vol Bit 1	Vol Bit 0

2.3.2 Mute

The application of mute ramps the volume from any setting to noiseless hard mute state. There are two methods in which the TAS5036B can be placed into mute. The TAS5036B is placed in the noiseless mute when the $\overline{\text{MUTE}}$ terminal is asserted low for a minimum of 3 MCLK_IN cycles. Alternatively, the mute mode can be initiated by setting the mute bit in the system control register through the serial control interface. The TAS5036B is held in mute state as long as the terminal is low or I²C mute setting is active. This command uses quiet entry and exit sequences to and from the hard mute state.

If an error recovery (described in the PWM section) occurs after a mute request has been received, the device returns from error recovery with the channel volume set as specified by the mute command.

2.3.3 Auto Mute

Automute is an automatic sequence that can be enabled or disabled via the serial control interface. The default for this control is enabled. When enabled, the PWM automutes an individual channel when a channel receives from 5 ms to 50 ms of consecutive zeros. This time interval can be selectable using the automute delay register. The default interval is 5 ms at 48 kHz. This duration is independent of the sample rate. The automute state is exited when two consecutive samples of nonzero data are received. The TAS5036B exit from automute is performed quickly and preserves all music information.

This mode uses the valid low to provide a low-noise floor while maintaining a short start-up time. Noise free entry and exit is achieved by using the PWM quiet start and stop sequences.

2.3.4 Individual Channel Mute

Individual channel mute is invoked through the serial interface. Individual channel mute permits each channel of the TAS5036B to be individually muted and unmuted. The operation that is performed is identical to the mute operation; however, it is performed on a per channel basis. A TAS5036B channel is held in the mute state as long as the serial interface mute setting for that channel is set.

2.3.5 De-Emphasis Filter

For audio sources that have been pre-emphasized, a precision 50- μ s/15- μ s de-emphasis filter is provided to support the sampling rates of 32 kHz, 44.1 kHz, and 48 kHz. See Figure 2–11 for a graph showing the de-emphasis filtering characteristics. De-emphasis is set using two bits in the system control register.

Table 2–10. De-Emphasis Filter Characteristics

DEM_SEL2 (MSB)	DEM_SEL1	DESCRIPTION
0	0	De-emphasis disabled
0	1	De-emphasis enabled for Fs = 48 kHz
1	0	De-emphasis enabled for Fs = 44 kHz
1	1	De-emphasis enabled for Fs = 32 kHz

Following the change of state of the de-emphasis bits, the PWM outputs go into the soft mute state. After 128 LRCLK periods for initialization, the PWM outputs are driven to the normal (unmuted) mode.

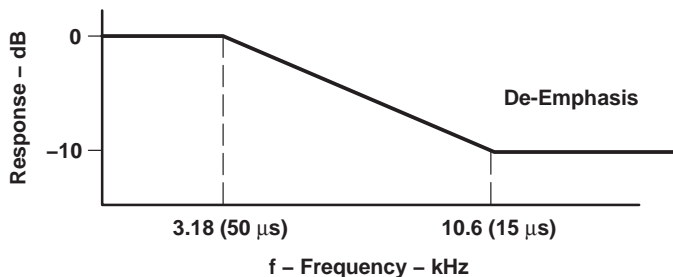

Figure 2–11. De-Emphasis Filter Characteristics

2.4 Pulse Width Modulator (PWM)

The TAS5036B contains six channels of high performance digital Equibit PWM modulators that are designed to drive switching output stages (back ends) in both single-ended (SE) and H-bridge (bridge tied load) configuration. The TAS5036B device uses noise shaping and sophisticated error correction algorithms to achieve high power efficiency and high-performance digital audio reproduction.

The PWM provides six pseudo-differential outputs to drive six monolithic power stages (such as TAS5110) or six discrete differential power stages using gate drivers (such as the TAS5182) and MOSFETs in single-ended or bridged configurations. The TAS5036B also provides a high performance differential output that can be used to drive an external analog headphone amplifier.

2.4.1 Clipping Indicator

The clipping output is designed to indicate clipping. When any of the six PWM outputs exceeds the maximum allowable amplitude, the clipping indicator is asserted. The clipping indicator is cleared every 10 ms.

2.4.2 Error Recovery

Error recovery is used to provide error management and to permit the PWM output to be reset while preserving all intervolume, interchannel delay, dc offsets, and the other internal settings. Error recovery is initiated by bringing the `ERR_RCVRY` terminal low for a minimum 5 MCLK_IN cycles or by setting the error recovery bit in control register 1. Error recovery is a level sensitive signal.

The device also performs an error recovery automatically:

- When the speed configuration is changed to normal, double, or quad speed
- Following a change in the serial data bus interface configuration

When `ERR_RCVRY` is brought low, all valid signals go low, and the PWM-P and PWM-M outputs go low. If there are any pending speed configurations, these changes are then performed. When `ERR_RCVRY` is brought high, a delay of 4 ms to 5 ms is performed before the system starts the output re-initialization sequence. After the initialization time, the TAS5036B begins normal operation. During error recovery, all controls and device settings that were not updated are maintained in their current configurations.

To permit error recovery to be used to provide TAS5100 error management and recovery, the delay between the start of (falling edge) error recovery and the falling edge of valid 1 though valid 6 is selectable. This delay can be selected to be either 6 μs or 47 μs.

During error recovery all serial data bus operations are ignored. At the conclusion of the sequence, the error recovery register bit is returned to normal operation state. Table 2–11 shows the device output signal states while during error recovery.

Table 2–11. Device Outputs During Error Recovery

SIGNAL	MODE	SIGNAL STATE
Valid 1–Valid 6	All	Low
PWM P-outputs	All	Low
PWM M-outputs	All	Low
MCLKOUT	All	Low
SCLK	Master	Low
SCLK	Slave	Signal input
LRCLK	Master	Low
LRCLK	Slave	Signal input
SDA	All	Signal input
CLIP	All	High

The transitions are done using a quiet entrance and exit sequence to prevent pops and clicks.

2.4.3 Individual Channel Error Recovery

Individual channel error recovery is used to provide error management and to permit the PWM output to be turned off. Error recovery is initiated by setting one or more of the six error recovery bits in the error recovery register to low.

While the error recover bits are brought low, the valid signals go to the low state. When the error recovery bits are brought high, a delay of 4 ms to 5 ms occurs before the channels are returned to normal operation.

The delay between the falling edge of the error recover bit and the falling edge of valid 1 through valid 6 is selectable. This delay can be selected to be either 6 μ s or 47 μ s.

The TAS5036B controls the relative timing of the pseudo-differential drive control signals plus the valid signal to minimize the production of system noise during error recovery operations. The transitions to valid low and valid high are done using an almost quiet entrance and exit sequence to prevent pops and clicks.

2.4.4 PWM DC-Offset Correction

An 8-bit value can be programmed to each of the six PWM offset correction registers to correct for any offset present in the output stages. The offset correction is divided into 256 intervals with a total offset correction of $\pm 1.56\%$ of full scale. The default value is zero correction represented by 00 (hex). These values can be changed at any time through the serial control interface.

2.4.5 Interchannel Delay

An 8-bit value can be programmed to each of the six PWM interchannel delay registers to add a delay per channel from 0 to 255 clock cycles. The delays correspond to cycles of the high-speed internal clock, DCLK (or alternatively the external PLL clock frequency). Each subsequent channel has a default value that is N DCLKs larger than the preceding channel. The default values are 0 for the first channel and 76 for each successive channel.

These values can be updated upon power up through the serial control interface. This delay is generated in the PWM block with the appropriate control signals generated in the CTL block.

These values can be changed at any time through the serial control interface.

2.4.6 ABD Delay

A 5-bit value is used to delay the A PWM signals with respect to B PWM signals. The value is the same for all channels. It can be programmed from 0 to 31 DCLK clock cycles. The default values is 17 DCLK clock cycles (01011). These values can be changed at any time through the serial control interface.

NOTE:

The performance of a TDAA system is optimized by setting the PWM timing based upon the type of back-end device that is used and the layout. These values are set during initialization using the I²C serial interface.

2.4.7 PWM/H-Bridge and Discrete H-Bridge Driver Interface

The TAS5036B provides six PWM outputs, which are designed to drive switching output stages (back-ends) in both single-ended (SE) and H-bridge (bridge tied load) configuration. The back-ends may be monolithic power stages (such as the TAS5110) or six discrete differential power stages using gate drivers (such as the TAS55182) and MOSFETs in single-ended or bridged configurations.

The TAS5110 device is optimized for bridge tied load (BTL) configurations. These devices require a pure differential PWM signal with a third signal (VALID) to control the MUTE state. In the MUTE state, the TAS5110 OUTA and OUTB are both low.

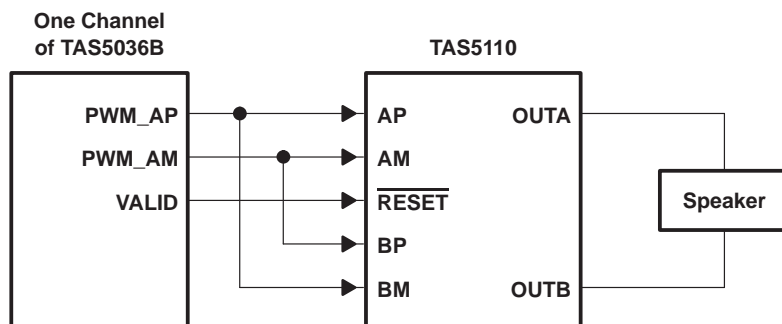

Figure 2–12. PWM Outputs and H-Bridge Driven in BTL Configuration

2.5 I²C Serial Control Interface

MCLK must be active for the TAS5036B to support I²C bus transactions. The TAS5036B has a bidirectional serial control interface that is compatible with the I²C (Inter IC) bus protocol and supports both 100 KBPS and 400 KBPS data transfer rates for single and multiple byte write and read operations. This is a slave only device that does not support a multi-master bus environment or wait state insertion. The control interface is used to program the registers of the device and to read device status.

The TAS5036B supports the standard-mode I²C bus operation (100 kHz maximum) and the fast I²C bus operation (400 kHz maximum). The TAS5036B performs all I²C operations without I²C wait cycles.

The I²C bus employs two signals; SDA (data) and SCL (clock), to communicate between integrated circuits in a system. Data is transferred on the bus serially one bit at a time. The address and data are transferred in byte (8 bit) format with the most significant bit (MSB) transferred first. In addition, each byte transferred on the bus is acknowledged by the receiving device with an acknowledge bit. Each transfer operation begins with the master device driving a start condition on the bus and ends with the master device driving a stop condition on the bus. The bus uses transitions on the data terminal (SDA) while the clock is high to indicate start and stop conditions. A high-to-low transition on SDA indicates a start, and a low-to-high transition indicates a stop. Normal data bit transitions must occur within the low time of the clock period. These conditions are shown in Figure 2–13. The master generates the 7-bit slave address and the read/write (R/W) bit to open communication with another device and then waits for an acknowledge condition. The TAS5036B holds SDA low during acknowledge clock period to indicate an acknowledgement. When this occurs, the master transmits the next byte of the sequence. Each device is addressed by a unique 7-bit slave address plus R/W bit (1 byte). All compatible devices share the same signals via a bidirectional bus using a wired-AND connection. I²C An external pullup resistor must be used for the SDA and SCL signals to set the high level for the bus.

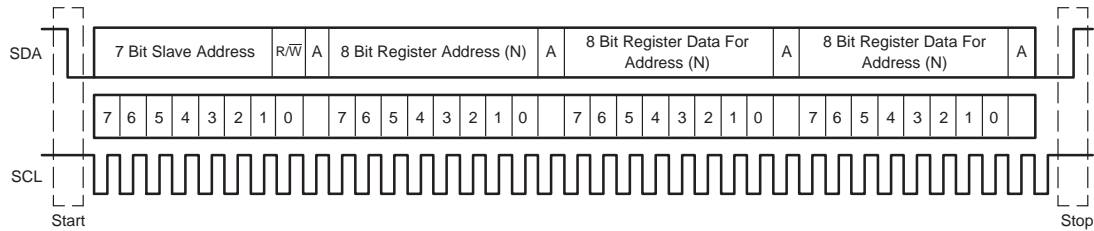

Figure 2–13. Typical I²C Sequence

There are no limits on the number of bytes that can be transmitted between start and stop conditions. When the last word transfers, the master generates a stop condition to release the bus. A generic data transfer sequence is also shown in Figure 2–13.

The 7-bit address for the TAS5036B is 001101X, where X is a programmable address bit. Using the CS0 terminal on the device, the LSB address bit is programmable to permit two devices to be used in a system. These two addresses are licensed I²C addresses and do not conflict with other licensed I²C audio devices. To communicate with the TAS5036B, the I²C master uses 0011010 if CS0=0 and 0011011 if CS0=1. In addition to the 7-bit device address, an 8-bit register address is used to direct communication to the proper register location within the device interface.

Read and write operations to the TAS5036B can be done using single byte or multiple byte data transfers.

2.5.1 Single Byte Write

As shown in Figure 2–14, a single byte data write transfer begins with the master device transmitting a start condition followed by the I²C device address and the read/write bit. The read/write bit determines the direction of the data transfer. For a write data transfer, the read/write bit is 0. After receiving the correct I²C device address and the read/write bit, the TAS5036B device responds with an acknowledge bit. Next, the master transmits the address byte or bytes corresponding to the TAS5036B internal memory address being accessed. After receiving the address byte, the TAS5036B again responds with an acknowledge bit. Next, the master device transmits the data byte to be written to the memory address being accessed. After receiving the data byte, the TAS5036B again responds with an acknowledge bit. Finally, the master device transmits a stop condition to complete the single byte data write transfer.

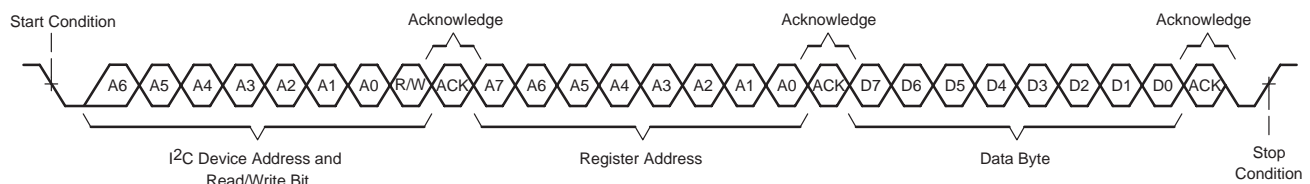

Figure 2–14. Single Byte Write Transfer

2.5.2 Multiple Byte Write

A multiple byte data write transfer is identical to a single byte data write transfer except that multiple data bytes are transmitted by the master device to TAS5036B as shown in Figure 2–15. After receiving each data byte, the TAS5036B responds with an acknowledge bit.

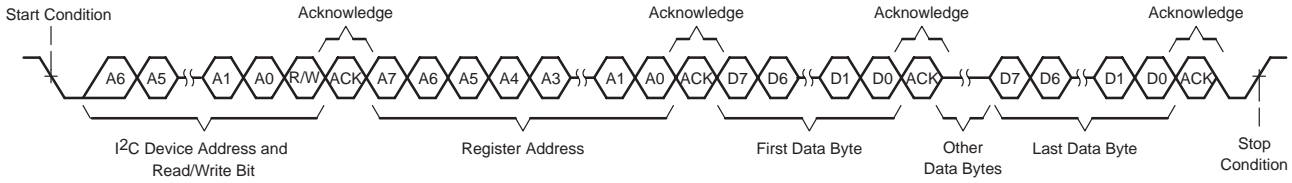

Figure 2–15. Multiple Byte Write Transfer

2.5.3 Single Byte Read

As shown in Figure 2–16, a single byte data read transfer begins with the master device transmitting a start condition followed by the I²C device address and the read/write bit. For the data read transfer, a write followed by a read are actually done. Initially, a write is done to transfer the address byte or bytes of the internal memory address to be read. As a result, the read/write bit is 0. After receiving the TAS5036B address and the read/write bit, the TAS5036B responds with an acknowledge bit. Also, after sending the internal memory address byte or bytes, the master device transmits another start condition followed by the TAS5036B address and the read/write bit again. This time the read/write bit is a 1 indicating a read transfer. After receiving the TAS5036B and the read/write bit, the TAS5036B again responds with an acknowledge bit. Next, the TAS5036B transmits the data byte from the memory address being read. After receiving the data byte, the master device transmits a not acknowledge followed by a stop condition to complete the single byte data read transfer.

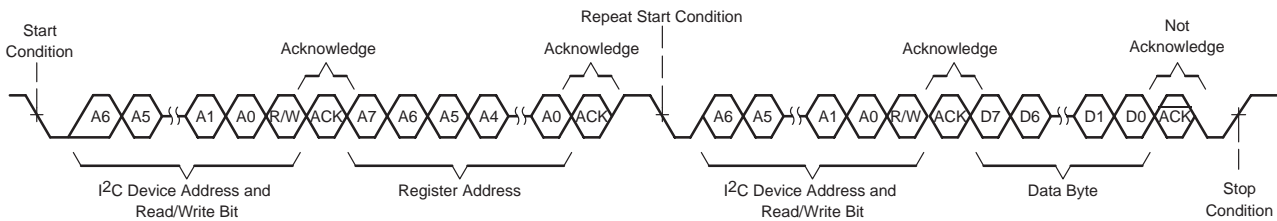

Figure 2–16. Single Byte Read

2.5.4 Multiple Byte Read

A multiple byte data read transfer is identical to a single byte data read transfer except that multiple data bytes are transmitted by the TAS5036B to the master device as shown in Figure 2–17. Except for the last data byte, the master device responds with an acknowledge bit after receiving each data byte.

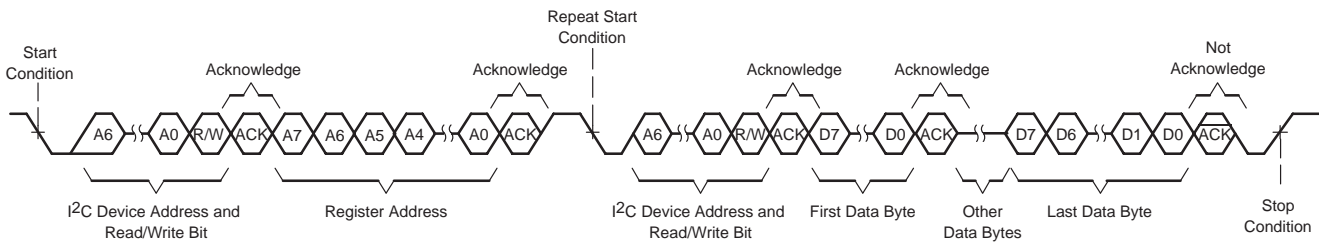

Figure 2–17. Multiple Byte Read

3 Serial Control Interface Register Definitions

Table 3–1 shows the register map for the TAS5036B. Default values in this section are in bold.

Table 3–1. I²C Register Map

ADDR HEX	DESCRIPTION
00	General status register
01	Error status register
02	System control register 0
03	System control register 1
04	Error recovery register
05	Automute delay
06	DC-offset control register channel 1
07	DC-offset control register channel 2
08	DC-offset control register channel 3
09	DC-offset control register channel 4
0A	DC-offset control register channel 5
0B	DC-offset control register channel 6
0C	Interchannel delay register channel 1
0D	Interchannel delay register channel 2
0E	Interchannel delay register channel 3
0F	Interchannel delay register channel 4
10	Interchannel delay register channel 5
11	Interchannel delay register channel 6
12	ABD delay register
13	Volume control register channel 1
14	Volume control register channel 2
15	Volume control register channel 3
16	Volume control register channel 4
17	Volume control register channel 5
18	Volume control register channel 6
19	Individual channel mute

The volume table is contained in Appendix A.

Default values are shown in bold in the following tables.

3.1 General Status Register (x00)

Table 3–2. General Status Register (Read Only)

D7	D6	D5	D4	D3	D2	D1	D0	FUNCTION
0	-	-	-	-	-	-	-	No volume update is in progress.
1	-	-	-	-	-	-	-	Volume update is in progress.
-	0	-	-	-	-	-	-	Always 0
-	-	1	0	0	1	1	-	Device identification code
-	-	-	-	-	-	-	0	Any valid signal is inactive (see status register (X03)) (see Note 1).
-	-	-	-	-	-	-	1	No internal errors (all valid signals are high)

NOTE 1: This bit is reset automatically when one or more channels are active.

3.2 Error Status Register (x01)

Table 3–3. Error Status Register

D7	D6	D5	D4	D3	D2	D1	D0	FUNCTION
1	-	-	-	-	-	-	-	FS error has occurred
-	1	-	-	-	-	-	-	Control pin change has occurred
-	-	-	1	-	-	-	-	LRCLK error
-	-	-	-	1	-	-	-	MCLK_IN count error
-	-	-	-	-	1	-	-	DCLK phase error with respect to MCLK_IN
-	-	-	-	-	-	1	-	MCLK_IN phase error with respect to DCLK
-	-	-	-	-	-	-	1	PWM timing error
0	0	0	0	0	0	0	0	No errors—no control pins changed

NOTE 2: Write 00 hex to clear error indications in Error Status Register.

3.3 System Control Register 0 (x02)

Table 3–4. System Control Register 0

D7	D6	D5	D4	D3	D2	D1	D0	FUNCTION
0	0	-	-	-	-	-	-	Normal mode (in slave mode—quad speed detected if MCLK_IN = 128 Fs)
0	1	-	-	-	-	-	-	Double speed
1	0	-	-	-	-	-	-	Quad speed
1	1	-	-	-	-	-	-	Illegal
-	-	0	-	-	-	-	-	Use de-emphasis pin controls
-	-	1	-	-	-	-	-	Use de-emphasis I2C controls
-	-	-	0	0	-	-	-	No de-emphasis
-	-	-	0	1	-	-	-	De-emphasis for Fs = 32 kHz
-	-	-	1	0	-	-	-	De-emphasis for Fs = 44.1 kHz
-	-	-	1	1	-	-	-	De-emphasis for Fs = 48 kHz
-	-	-	-	-	0	0	0	16 bit, MSB first; right justified
-	-	-	-	-	0	0	1	20 bit, MSB first; right justified
-	-	-	-	-	0	1	0	24 bit, MSB first; right justified
-	-	-	-	-	0	1	1	16-bit IIS
-	-	-	-	-	1	0	0	20-bit IIS
-	-	-	-	-	1	0	1	24-bit IIS
-	-	-	-	-	1	1	0	16-bit MSB first
-	-	-	-	-	1	1	1	16-bit DSP Frame

3.4 System Control Register 1 (x03)

Table 3–5. System Control Register 1

D7	D6	D5	D4	D3	D2	D1	D0	FUNCTION
0	-	-	-	-	-	-	-	RESERVED – Set to 0 in all cases
-	-	-	-	-	-	-	-	
-	0	-	-	-	-	-	-	Valid remains high during automute.
-	1	-	-	-	-	-	-	Valid goes low during automute.
-	-	0	-	-	-	-	-	Valid remains high during mute.
-	-	1	-	-	-	-	-	Valid goes low during mute.
-	-	-	0	-	-	-	-	Mute
-	-	-	1	-	-	-	-	Normal mode
-	-	-	-	0	-	-	-	Set error recovery delay at 6 μ s
-	-	-	-	1	-	-	-	Set error recovery delay at 47 μ s
-	-	-	-	-	0	-	-	Error recovery (forces error recovery initialization sequence)
-	-	-	-	-	1	-	-	Normal mode
-	-	-	-	-	-	0	-	Automute disabled
-	-	-	-	-	-	1	-	Automute enabled
-	-	-	-	-	-	-	-	
-	-	-	-	-	-	-	0	RESERVED – Set to 0 in all cases

3.5 Error Recovery Register (x04)

Table 3–6. Error Recovery Register

D7	D6	D5	D4	D3	D2	D1	D0	FUNCTION
1	1	-	-	-	-	-	-	Set to 11 under default conditions and when x00 is written into x1F
0	-	-	-	-	-	-	-	if x84 is written into x1F – Enable volume ramp up after an error recovery sequence is initiated by the ERR_RCVRY terminal or the I ² C error recovery command (register X03 bit D2)
1	-	-	-	-	-	-	-	if x84 is written into x1F – Disable volume ramp up after an error recovery sequence is initiated by the ERR_RCVRY terminal or the I ² C error recovery command (register X03 bit D2)
-	0	-	-	-	-	-	-	if x84 is written into x1F – Enable volume ramp up after error recovery sequence is initiated by register bits D5 – D0 of this register
-	1	-	-	-	-	-	-	if x84 is written into x1F – Enable volume ramp up after error recovery sequence is initiated by register bits D5 – D0 of this register
-	-	0	-	-	-	-	-	Put channel 6 into error recovery mode
-	-	-	0	-	-	-	-	Put channel 5 into error recovery mode
-	-	-	-	0	-	-	-	Put channel 4 into error recovery mode
-	-	-	-	-	0	-	-	Put channel 3 into error recovery mode
-	-	-	-	-	-	0	-	Put channel 2 into error recovery mode
-	-	-	-	-	-	-	0	Put channel 1 into error recovery mode
-	-	1	1	1	1	1	1	Normal operation

3.6 Automute Delay Register (x05)

Table 3–7. Automute Delay Register

D7	D6	D5	D4	D3	D2	D1	D0	FUNCTION
0	0	0	0	-	-	-	-	Unused
-	-	-	-	-	-	-	-	
-	-	-	-	0	0	0	0	Set automute delay at 5 ms
-	-	-	-	0	0	0	1	Set automute delay at 10 ms
-	-	-	-	0	0	1	0	Set automute delay at 15 ms
-	-	-	-	0	0	1	1	Set automute delay at 20 ms
-	-	-	-	0	1	0	0	Set automute delay at 25 ms
-	-	-	-	0	1	0	1	Set automute delay at 30 ms
-	-	-	-	0	1	1	0	Set automute delay at 35 ms
-	-	-	-	0	1	1	1	Set automute delay at 40 ms
-	-	-	-	1	-	-	0	Set automute delay at 45 ms
-	-	-	-	1	-	-	1	Set automute delay at 50 ms

3.7 DC-Offset Control Registers (x06–x0B)

Channels 1, 2, 3, 4, 5, and 6 are mapped into (x06, x07, x08, x09, x0A, and x0B).

Table 3–8. DC-Offset Control Registers

D7	D6	D5	D4	D3	D2	D1	D0	FUNCTION
1	0	0	0	0	0	0	0	Maximum correction for positive dc offset (–1.56% FS)
0	0	0	0	0	0	0	0	No dc-offset correction
0	1	1	1	1	1	1	1	Maximum correction for negative dc offset (1.56% FS)

3.8 Interchannel Delay Registers (x0C–x11)

Channels 1, 2, 3, 4, 5, and 6 are mapped into (x0C, x0D, x0E, x0F, x10, and x11).

The first channel delay is set at 0. Each subsequent channel has a default value that is 76 DCLKs larger than the preceding channel.

Table 3–9. Six Interchannel Delay Registers

D7	D6	D5	D4	D3	D2	D1	D0	FUNCTION
0	0	0	0	0	0	0	0	Minimum absolute delay, 0 DCLK cycles, default for channel 1
0	1	0	0	1	1	0	0	Default for channel 2
1	0	0	1	1	0	0	0	Default for channel 3
1	1	1	0	0	1	0	0	Default for channel 4
0	0	1	1	0	0	0	0	Default for channel 5
0	1	1	1	1	1	0	0	Default for channel 6
1	1	1	1	1	1	1	1	Maximum absolute delay, 255 DCLK cycles

3.9 ABD Delay Register (x12)

Table 3–10. ABD Delay Register

D7	D6	D5	D4	D3	D2	D1	D0	FUNCTION
0	0	0	-	-	-	-	-	Unused
-	-	-	-	-	-	-	-	
-	-	-	0	0	0	0	0	Minimum ABD delay, 0 DLCK cycles
-	-	-	1	0	0	0	1	Default ABD delay, 17 DLCK cycles
-	-	-	1	1	1	1	1	Maximum ABD delay, 31 DLCK cycles

3.10 Individual Channel Mute Register (x19)

Table 3–11. Individual Channel Mute Register

D7	D6	D5	D4	D3	D2	D1	D0	FUNCTION
1	1	-	-	-	-	-	-	Unused
-	-	-	-	-	-	-	-	
-	-	1	1	1	1	1	1	No channels are muted
-	-	-	-	-	-	-	0	Mute channel 1
-	-	-	-	-	-	0	-	Mute channel 2
-	-	-	-	-	0	-	-	Mute channel 3
-	-	-	-	0	-	-	-	Mute channel 4
-	-	-	0	-	-	-	-	Mute channel 5
-	-	0	-	-	-	-	-	Mute channel 6

4 System Procedures for Initialization, Changing Data Rates, and Switching Between Master and Slave Modes

4.1 System Initialization

Reset is used during system initialization to hold the TAS5036B inactive while power (VDD), the master clock (MCLK_IN), the device control, and the data signals become stable. The recommended initialization sequence is to hold $\overline{\text{RESET}}$ low for 24 MCLK_IN cycles after VDD has reached 3 V and the other control signals ($\overline{\text{MUTE}}$, $\overline{\text{PDN}}$, $\overline{\text{M_S}}$, $\overline{\text{ERR_RCVRY}}$, $\overline{\text{DBSPD}}$, and $\overline{\text{CS0}}$) are stable.

Figure 4–1 shows the recommended sequence and timing for the $\overline{\text{RESET}}$ terminal during system VDD voltage and MCLK.

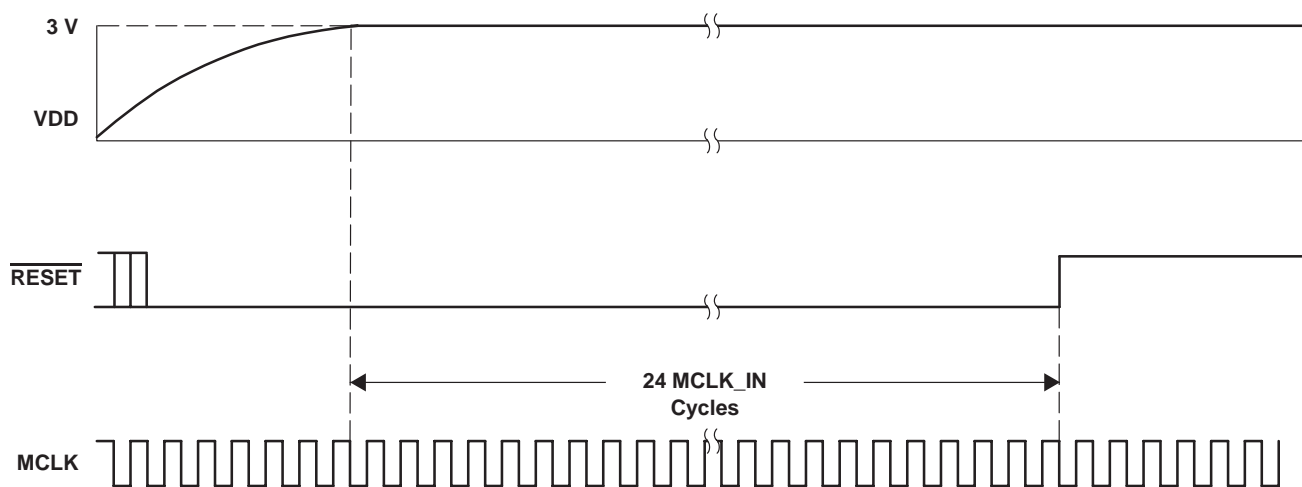

Figure 4–1. $\overline{\text{RESET}}$ During System Initialization

Within the first 2 ms following the low-to-high transition of the $\overline{\text{RESET}}$ terminal, the serial data interface format should be set in the serial data interface control register using the I²C serial control interface. If the data rate setting is other than the setting specified by the $\overline{\text{DBSPD}}$ terminal, then the data rate should be set using the $\overline{\text{DBSPD}}$ terminal or I²C interface within 2 ms. following the low-to-high transition of the $\overline{\text{RESET}}$ terminal.

The time available to set the I²C registers following the low-to-high transition of the $\overline{\text{RESET}}$ terminal can be extended using the $\overline{\text{ERR_RCVRY}}$ terminal. While $\overline{\text{ERR_RCVRY}}$ is low, the TAS5036B outputs are held inactive. Once the I²C control registers are set, the $\overline{\text{ERR_RCVRY}}$ terminal can be released and the TAS5036B starts operation. Figure 4–2 shows how the $\overline{\text{ERR_RCVRY}}$ terminal can be used to extend the interval as long as necessary to set the I²C registers following the low-to-high transition of the $\overline{\text{RESET}}$ terminal.

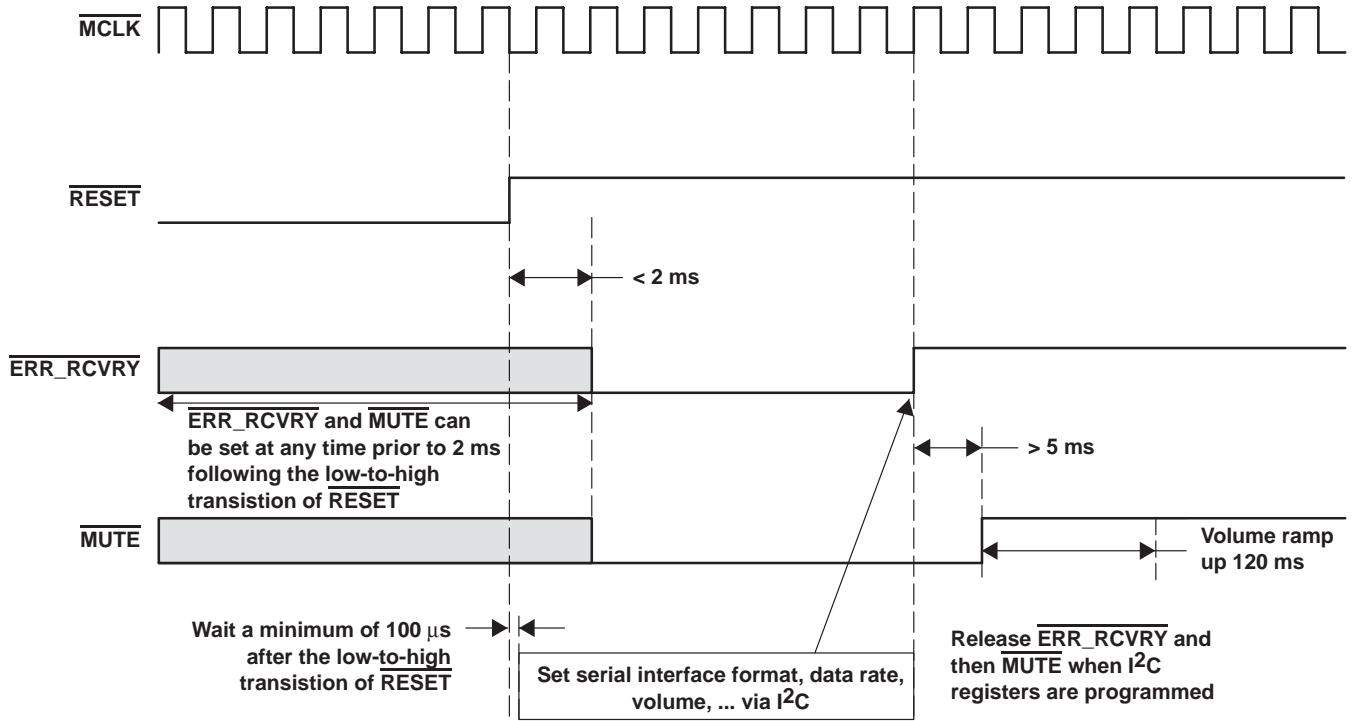

Figure 4–2. Extending the I²C Write Interval Following a Low-to-High Transition of the $\overline{\text{RESET}}$ Terminal

The operation of the TAS5036B can be tailored as desired to meet specific operating requirements by adjusting the following:

- Volume
- Data sample rate
- Emphasis/deemphasis settings
- Individual channel mute
- Automute delay register
- DC-offset control registers

If desired, the TAS5036B can be set to perform an unmute sequence following the low-to-high transition of the $\overline{\text{ERR_RCVRY}}$ terminal or the error recovery I²C command (register X03 bit D2). This capability is set by writing x7F to the individual error recovery register (x04) and an x84 to x1F (a feature enable register).

4.2 Data Sample Rate

If the master clock is well-behaved during the frequency transition (no MCLK_IN high or low clock periods less than 20 ns) then a simple speed selection is performed by setting the DBSPD terminal or the serial control register. If it is known at least 60 ms in advance that the sample rate is going to change, mute can be used to provide a completely silent transition. The timing of this control sequence is shown in Figure 4–3 and Figure 4–4.

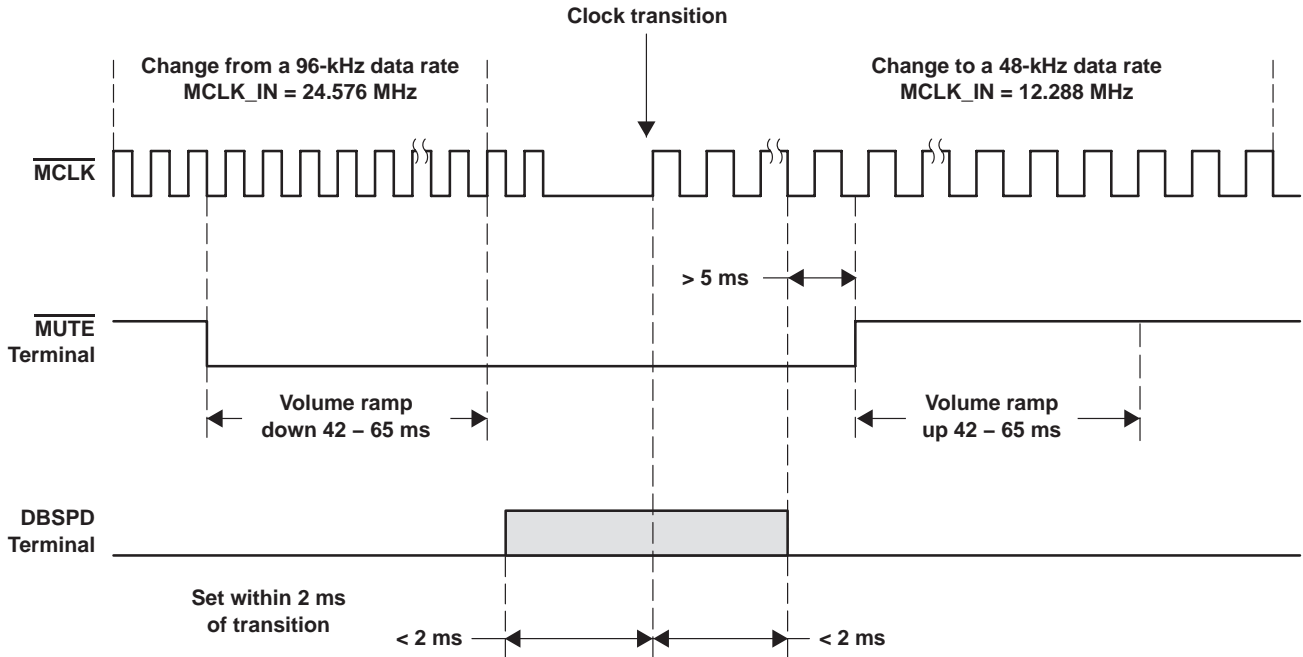

Figure 4-3. Changing the Data Sample Rate Using the DBSPD Terminal

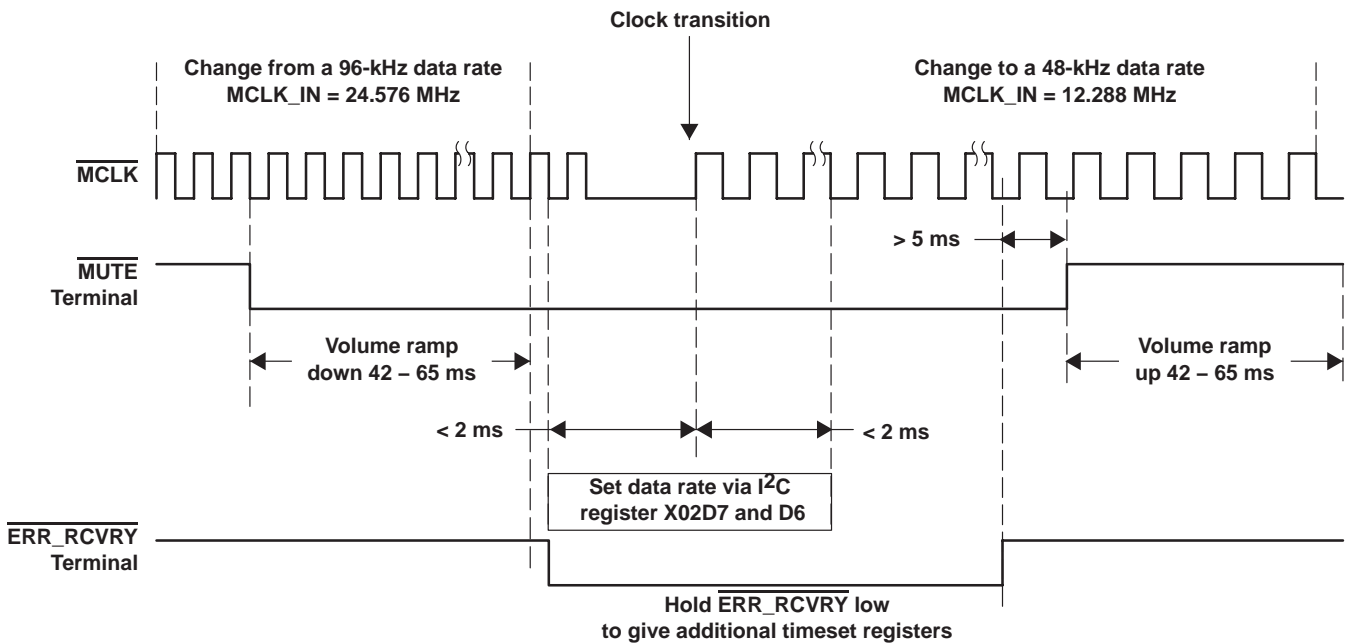

Figure 4-4. Changing the Data Sample Rate Using the I²C

However, if the master clock input can encounter a high clock or low clock period of less than 20 ns, then $\overline{\text{RESET}}$ should be applied during this time. There are two recommended control procedures for this case, depending upon whether the DBSPD terminal or the serial control interface is used. These control sequences are shown in Figure 4-5 and Figure 4-6.

Because this sequence employs the $\overline{\text{RESET}}$ terminal the internal register settings are set to the default values.

Figure 4–5 shows the procedure to change the data rate using the DBSPD terminal and then restore the register settings. In this example, the $\overline{\text{ERR_RCVRY}}$ terminal is used to hold off system re-initialization after $\overline{\text{RESET}}$ is released. This permits the system controller to have as much additional time as necessary to restore the register settings.

Once the data rate is set, the $\overline{\text{ERR_RCVRY}}$ and $\overline{\text{MUTE}}$ terminal signals are set high and the system re-initializes.

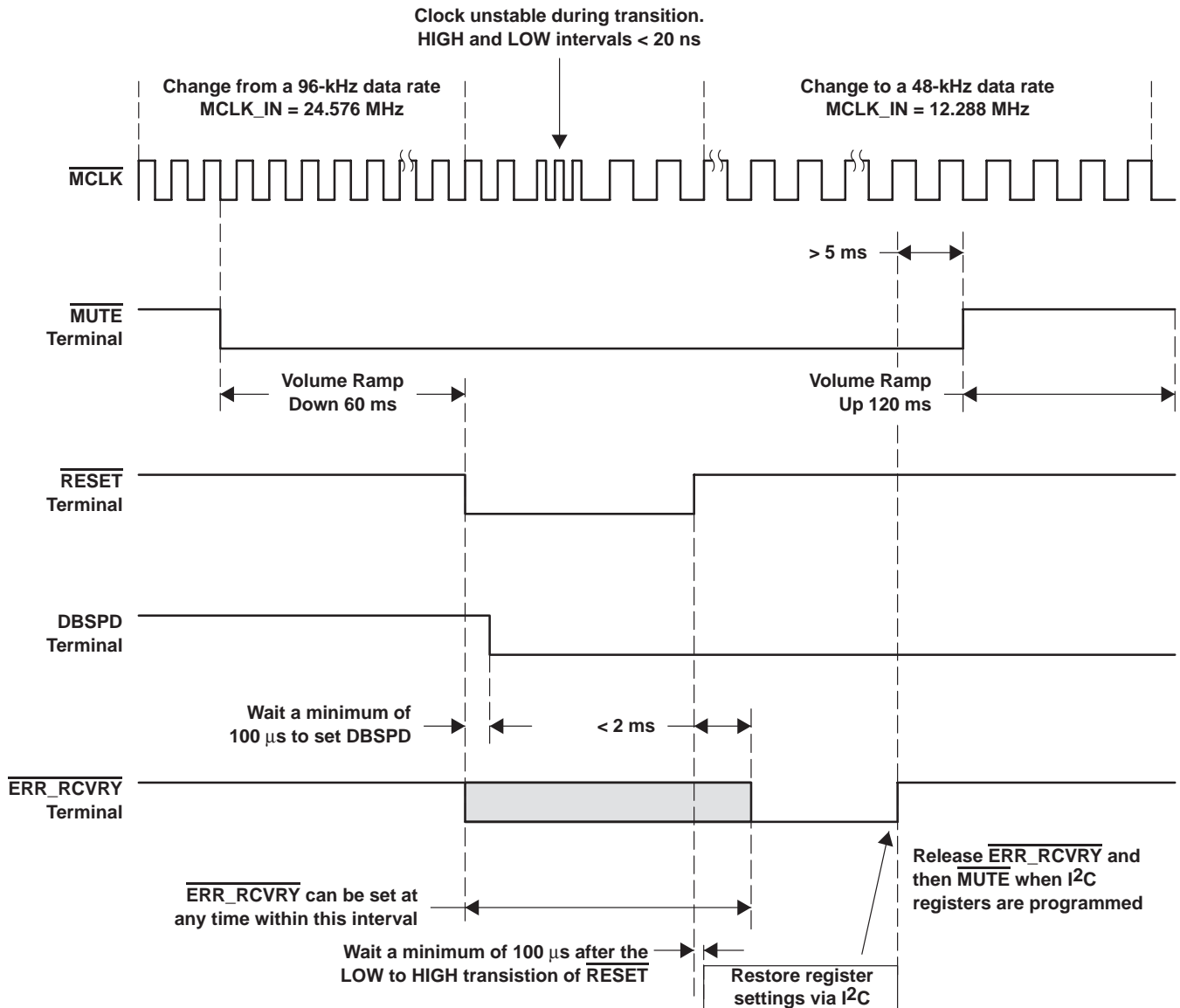

Figure 4–5. Changing the Data Sample Rate With An Unstable MCLK_IN Using the DBSPD Terminal

Because this sequence employs the $\overline{\text{RESET}}$ terminal, the internal register settings are set to the default values.

Figure 4–6 shows the procedure to change the data rate using register X02 D7 and D6 and then restore the other register settings. In this example, the $\overline{\text{ERR_RCVRY}}$ terminal is used to hold off system re-initialization after $\overline{\text{RESET}}$ is released. This permits the system controller to have as much additional time as necessary to restore the register settings.

Once the data rate is set, the $\overline{\text{ERR_RCVRY}}$ and $\overline{\text{MUTE}}$ terminal signals are set high and the system re-initializes.

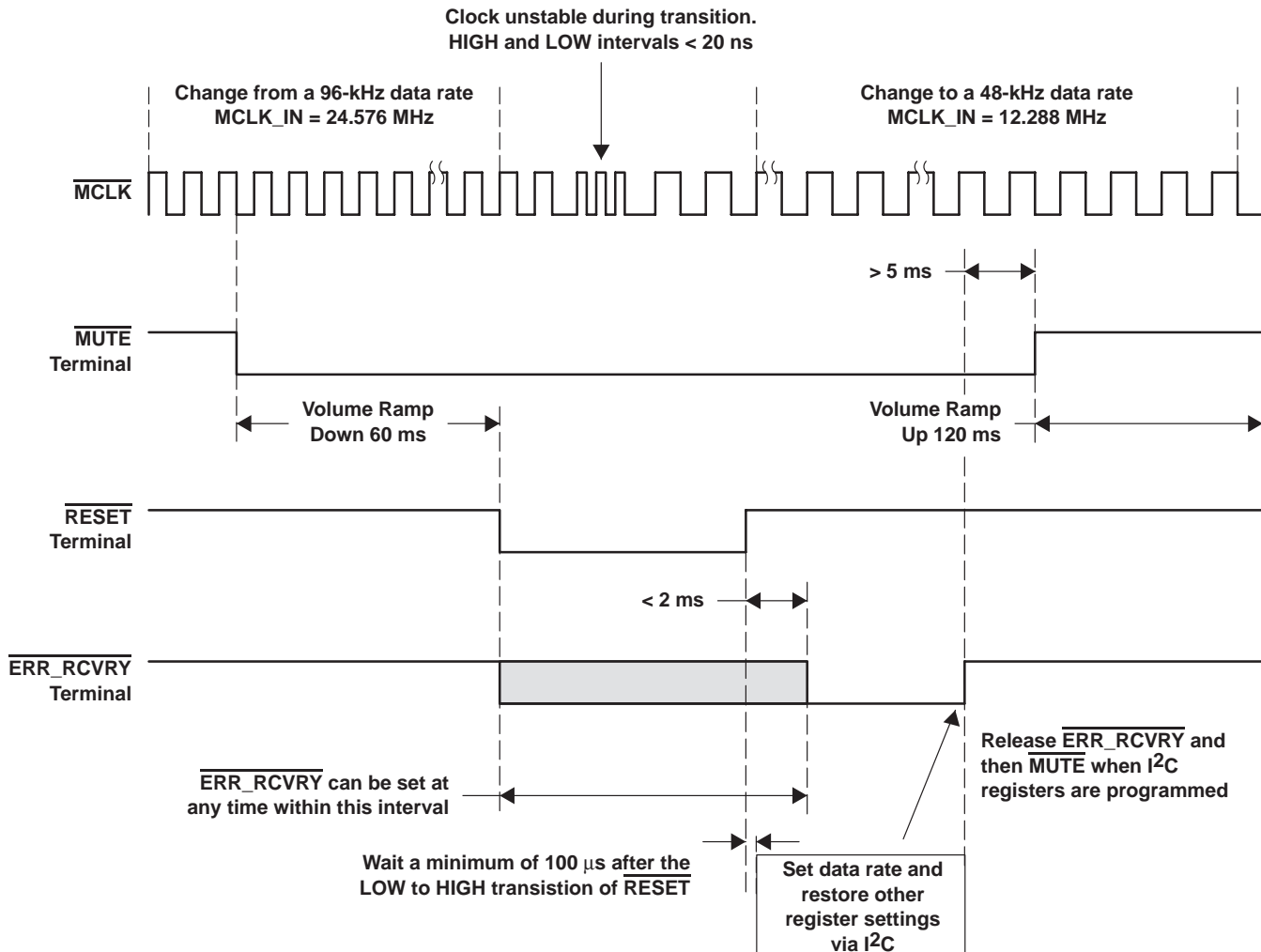

Figure 4–6. Changing the Data Sample Rate With An Unstable MCLK_IN Using the I²C

4.3 Changing Between Master and Slave Modes

The master and slave mode is set while the $\overline{\text{RESET}}$ terminal is active. Because this sequence employs the $\overline{\text{RESET}}$ terminal the internal register settings are set to the default values.

Figure 4–7 shows the procedure to switch between master and slave modes and then restore the register settings. In this example, the $\overline{\text{ERR_RCVRY}}$ terminal is used to hold off system re-initialization after $\overline{\text{RESET}}$ is released. This permits the system controller to have as much additional time as necessary to restore the register settings.

Once the data rate is set, the $\overline{\text{ERR_RCVRY}}$ and $\overline{\text{MUTE}}$ terminal signals are set high and the system re-initializes.

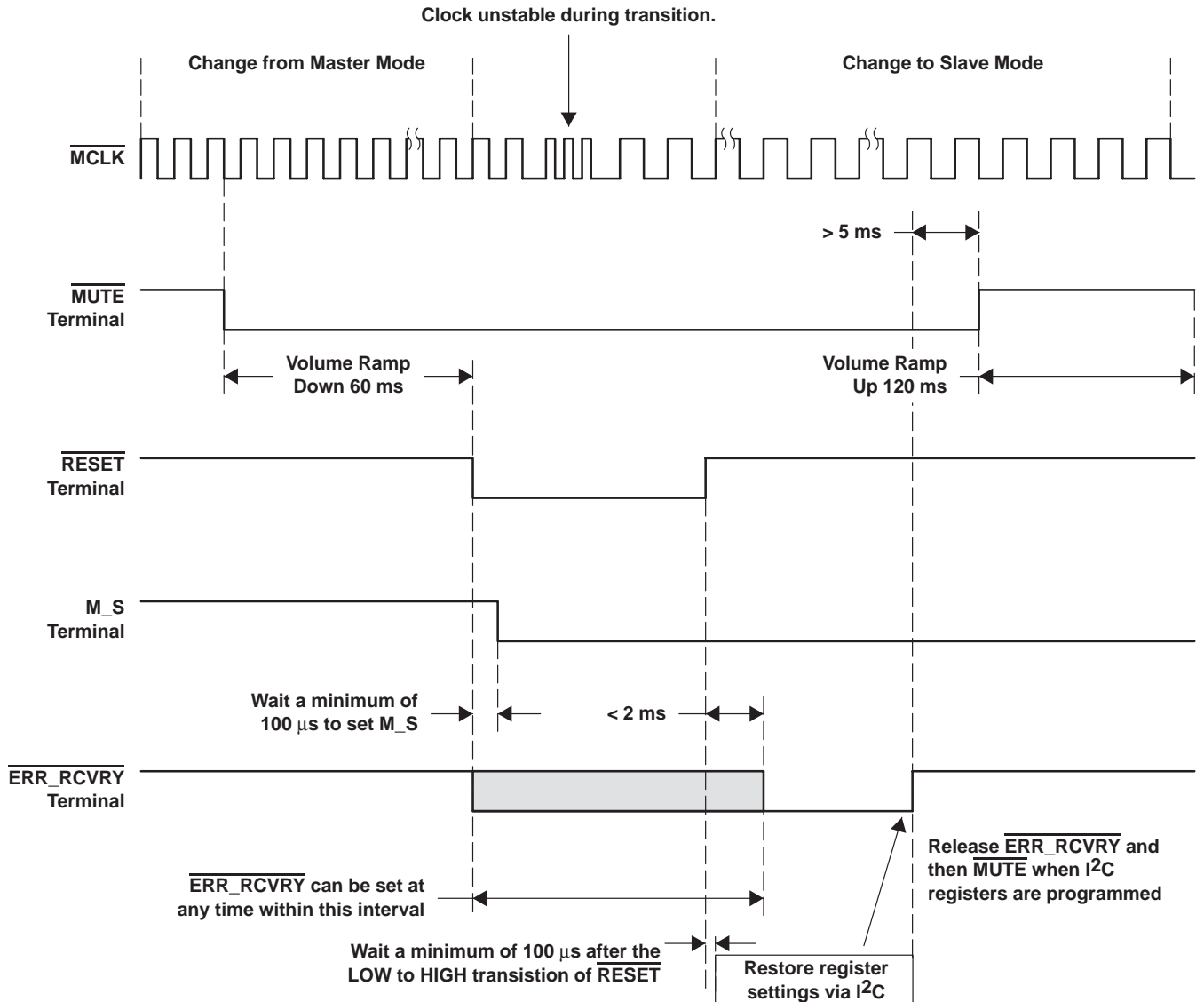

Figure 4–7. Changing Between Master and Slave Clock Mode

5 Specifications

5.1 Absolute Maximum Ratings Over Operating Temperature Ranges (Unless Otherwise Noted)[†]

Digital supply voltage range: DVDD_CORE, DVDD_PWM, DVDD_RCL	-0.3 V to 4.2 V
Analog supply voltage range: AVDD_PLL, ADD_OSC	-0.3 V to 4.2 V
Digital input voltage range, V _I	-0.3 V to DVDDX + 0.3 V
Operating free-air temperature	0°C to 70°C
Storage temperature range, T _{stg}	-65°C to 150°C
ESD	2000 V

[†] Stresses beyond those listed under “absolute maximum ratings” may cause permanent damage to the device. These are stress ratings only, and functional operation of the device at these or any other conditions beyond those indicated under “recommended operating conditions” is not implied. Exposure to absolute-maximum-rated conditions for extended periods may affect device reliability.

5.2 Recommended Operating Conditions (Fs = 48 kHz)

			MIN	TYP	MAX	UNIT
Supply voltage	Digital	DV _{DDX} , See Note 1	3	3.3	3.6	V
Supply current	Digital	Operating	60			mA
		Power down, See Note 2	25			μA
Power dissipation	Digital	Operating	200			mW
		Power down	100			μW
Supply voltage	Analog	AV _{DDX} , See Note 3	3	3.3	3.6	V
Supply current	Analog	Operating	10			mA
		Power down, See Note 2	25			μA
Power dissipation	Analog	Operating	35			mW
		Power down, See Note 2	100			μW

NOTES: 3. DVDD_CORE, DVDD_PWM, DVDD_RCL
 4. If the clocks are turned off.
 5. AVDD_PLL, AVDD_OSC

5.3 Electrical Characteristics Over Recommended Operating Conditions (Unless Otherwise Noted)

5.3.1 Static Digital Specifications Over Recommended Operating Conditions (Unless Otherwise Noted)

PARAMETER		TEST CONDITIONS	MIN	MAX	UNIT
V _{IH}	High-level input voltage		2	DVDD1	V
V _{IL}	Low-level input voltage		0	0.8	V
V _{OH}	High-level output voltage	I _O = -1 mA	2.4		V
V _{OL}	Low-level output voltage	I _O = 4 mA		0.4	V
I _{lkg}	Input leakage current		-10	10	μA

5.3.2 Digital Interpolation Filter and PWM Modulator Over Recommended Operating Conditions (Unless Otherwise Noted) Fs = 48 kHz

PARAMETER		TEST CONDITIONS	MIN	TYP	MAX	UNIT
Pass band			0		20	kHz
Pass band ripple			±0.012			dB
Stop band			24.1			kHz
Stop band attenuation		24.1 kHz to 152.3 kHz	50			dB
Group delay			700			μs
PWM modulation index (gain)			0.93%			

5.3.3 TAS5036B/TAS5182 System Performance Measured at the Speaker Terminals Over Recommended Operating Conditions (Unless Otherwise Noted)
F_s = 48 kHz

PARAMETER	TEST CONDITIONS	MIN	TYP	MAX	UNIT
SNR (EIAJ)	A-weighted		100		dB
Dynamic range	A-weighted, -60 dB, f = 1 kHz, 20 Hz–20 kHz		100		dB
THD+N	0 dB, 1 kHz, 20 Hz–20 kHz		0.09%		

5.4 Switching Characteristics

5.4.1 Command Sequence Timing

5.4.1.1 Reset Timing— $\overline{\text{RESET}}$

CONTROL SIGNAL PARAMETERS OVER RECOMMENDED OPERATING CONDITIONS (UNLESS OTHERWISE NOTED)					
PARAMETER	TEST CONDITIONS	MIN	TYP	MAX	UNIT
$t_w(\overline{\text{RESET}})$	Pulses duration, RESET active	50			ns
$t_p(\text{VALID_LOW})$	Propagation delay			1	μs
$t_p(\text{VALID_HIGH})$	Propagation delay	4		5	ms
$t_d(\text{VOLUME})$	Delay time	42		65	ms

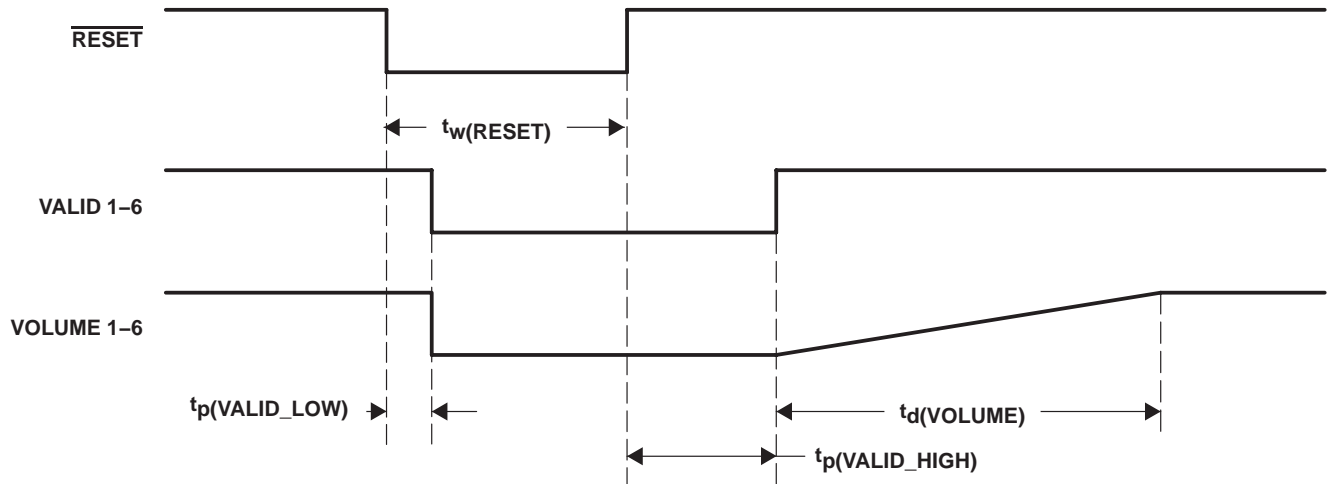

Figure 5–1. $\overline{\text{RESET}}$ Timing

5.4.1.2 Power-Down Timing— $\overline{\text{PDN}}$

5.4.1.2.1 Long Recovery

CONTROL SIGNAL PARAMETERS OVER RECOMMENDED OPERATING CONDITIONS (UNLESS OTHERWISE NOTED)					
PARAMETER	TEST CONDITIONS	MIN	TYP	MAX	UNIT
$t_w(\text{PDN})$	Pulse duration, PDN active	50			ns
$t_d(\text{R PDNR})$	Reset high to PDN rising edge	16 MCLKS			ns
$t_p(\text{VALID_LOW})$				1	μs
$t_p(\text{VALID_HIGH})$		85		100	ms
$t_d(\text{VOLUME})$		42		65	ms

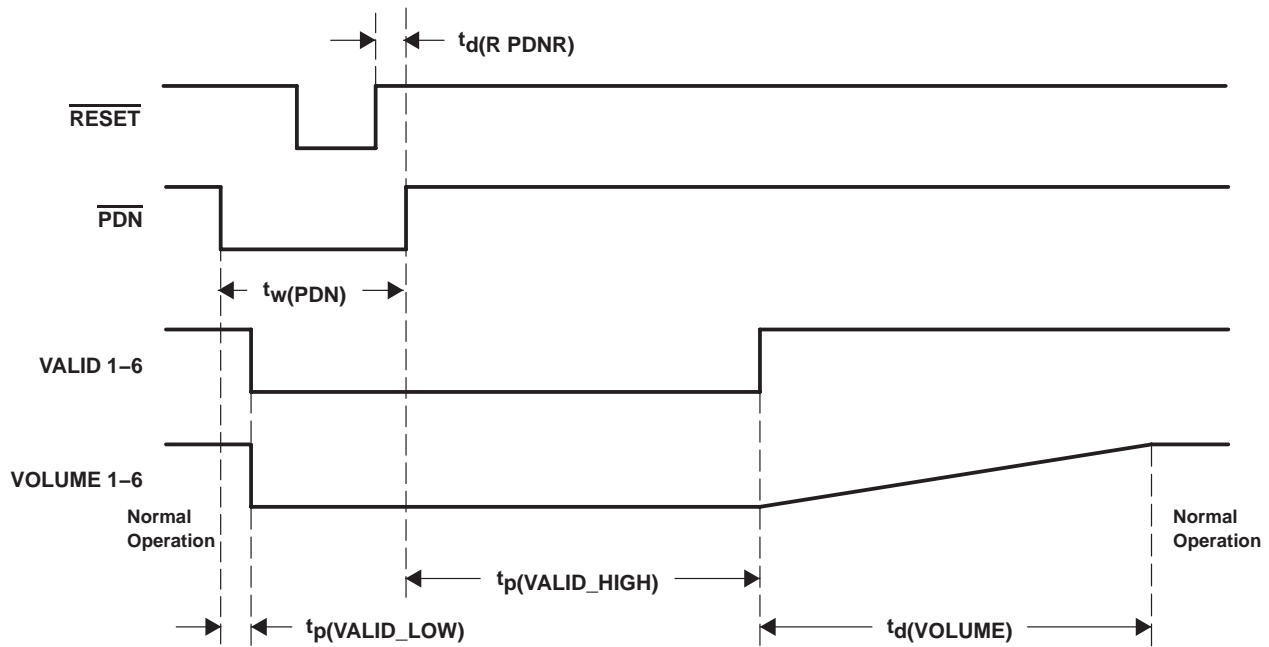
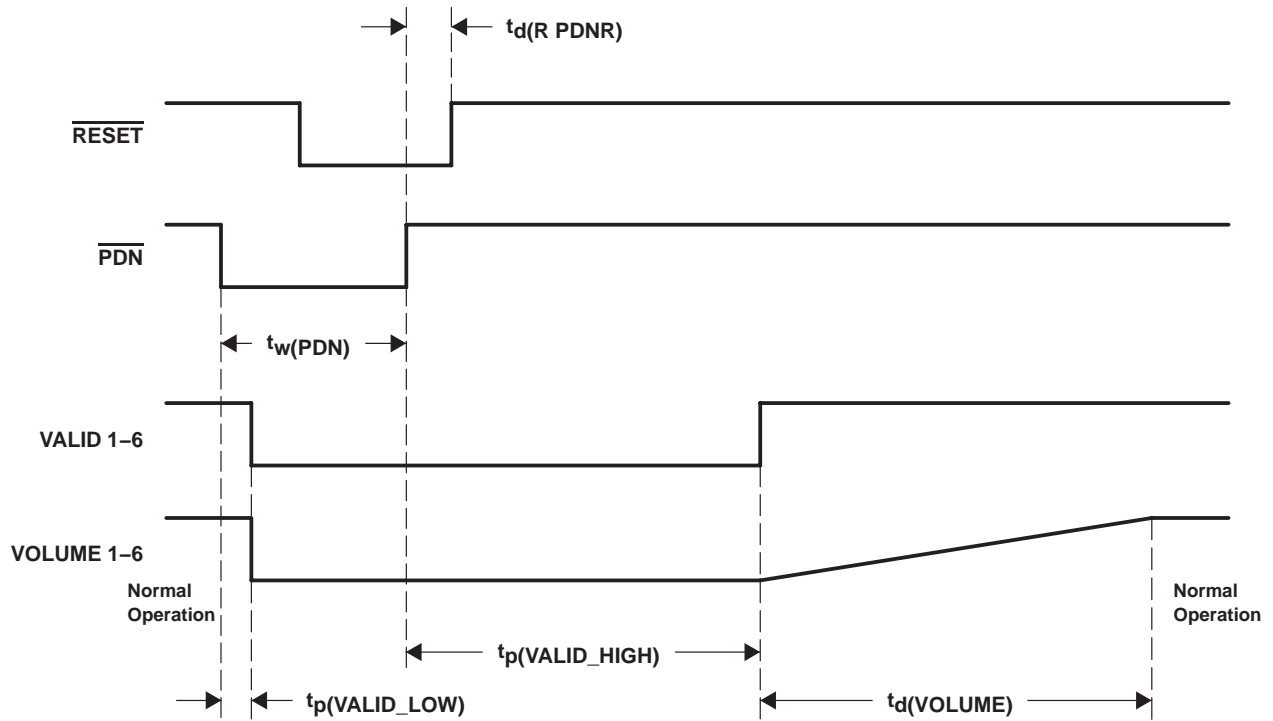

Figure 5–2. Power-Down and Power-Up Timing— $\overline{\text{RESET}}$ Preceding $\overline{\text{PDN}}$

5.4.1.2.2 Short Recovery

CONTROL SIGNAL PARAMETERS OVER RECOMMENDED OPERATING CONDITIONS (UNLESS OTHERWISE NOTED)					
PARAMETER	TEST CONDITIONS	MIN	TYP	MAX	UNIT
$t_w(\text{PDN})$	Pulse duration, PDN active	50			ns
$t_d(\text{R PDNR})$	PDN high to reset rising edge	16 MCLKS			ns
$t_p(\text{VALID_LOW})$				1	μs
$t_p(\text{VALID_HIGH})$		4		5	ms
$t_d(\text{VOLUME})$		42		65	ms

Figure 5-3. Power-Down and Power-Up Timing— $\overline{\text{RESET}}$ Following $\overline{\text{PDN}}$ 5.4.1.3 Error Recovery Timing— $\overline{\text{ERR_RCVRY}}$

CONTROL SIGNAL PARAMETERS OVER RECOMMENDED OPERATING CONDITIONS (UNLESS OTHERWISE NOTED)					
PARAMETER	TEST CONDITIONS	MIN	TYP	MAX	UNIT
$t_w(\text{ER})$	Pulse duration, ERR_RCVRY active	5 MCLKS			ns
$t_p(\text{VALID_LOW})$	Selectable for minimum or maximum	6		47	μs
$t_p(\text{VALID_HIGH})$		4		5	ms

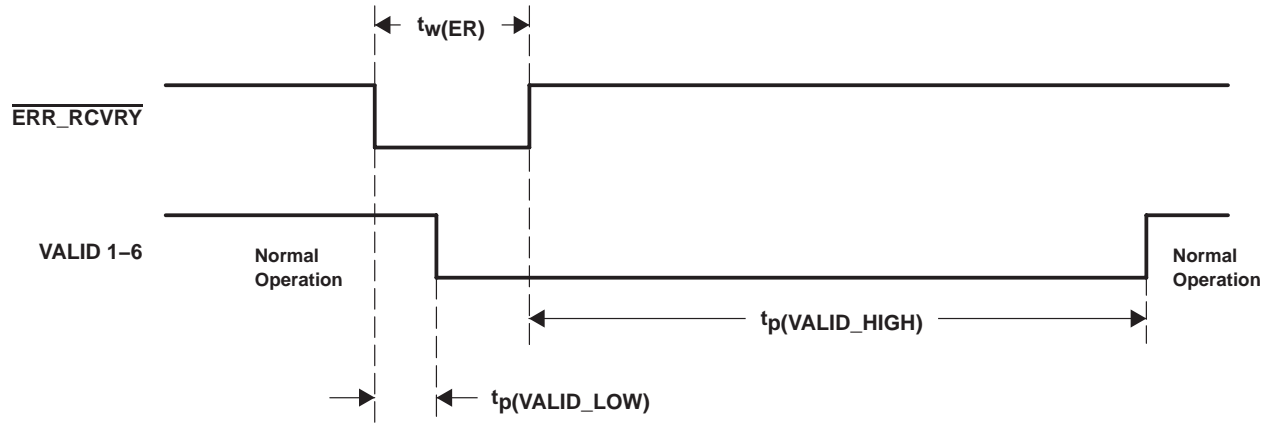

Figure 5-4. Error Recovery Timing

5.4.1.4 MUTE Timing— $\overline{\text{MUTE}}$

CONTROL SIGNAL PARAMETERS OVER RECOMMENDED OPERATING CONDITIONS (UNLESS OTHERWISE NOTED)						
PARAMETER		TEST CONDITIONS	MIN	TYP	MAX	UNIT
$t_w(\text{MUTE})$	Pulse duration, PDN active		3 MCLKS			ns
$t_d(\text{VOL})$				42		ms

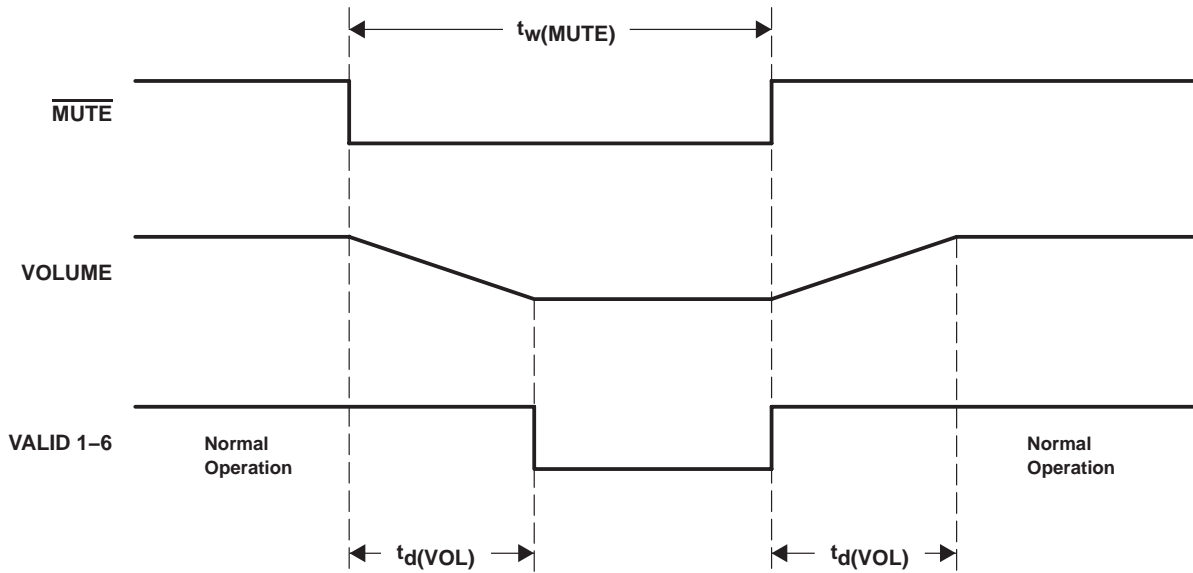

Figure 5-5. Mute Timing

5.4.2 Serial Audio Port

5.4.2.1 Serial Audio Ports Slave Mode Over Recommended Operating Conditions (Unless Otherwise Noted)

PARAMETER		MIN	TYP	MAX	UNIT
$f_{\text{(SCLK)}}$	Frequency, SCLK			12.288	MHz
$t_{\text{su}}(\text{SDIN})$	SDIN setup time before SCLK rising edge	20			ns
$t_{\text{h}}(\text{SDIN})$	SDIN hold time before SCLK rising edge	10			ns
$f_{\text{(LRCLK)}}$	LRCLK frequency	32	48	192	kHz
	MCLK_IN duty cycle		50%		
	SCLK duty cycle		50%		
	LRCLK duty cycle		50%		
$t_{\text{su}}(\text{LRCLK})$	LRCLK setup time before SCLK rising edge	20			ns
	MCLK high and low time	20			ns

5.4.2.2 Serial Audio Ports Master Mode, Load Conditions 50 pF Over Recommended Operating Conditions (Unless Otherwise Noted)

PARAMETER		MIN	TYP	MAX	UNIT
$t_{\text{(MSD)}}$	MCLK_IN to SCLK	0		5	ns
$t_{\text{(MLRD)}}$	MCLK_IN to LRCLK	0		5	ns

5.4.2.3 DSP Serial Interface Mode Over Recommended Operating Conditions (Unless Otherwise Noted)

PARAMETER		MIN	TYP	MAX	UNIT
$f_{\text{(SCLK)}}$	SCLK frequency			12.288	MHz
$t_{\text{d}}(\text{FS})$	Delay time, SCLK rising to F_s				ns
$t_{\text{w}}(\text{FSHIGH})$	Pulse duration, sync		$1/(64 \times f_s)$		ns
$t_{\text{su}}(\text{SDIN})$	SDIN and LRCLK setup time before SCLK falling edge	20			ns
$t_{\text{h}}(\text{SDIN})$	SDIN and LRCLK hold time from SCLK falling edge	10			ns
	SCLK duty cycle		50%		

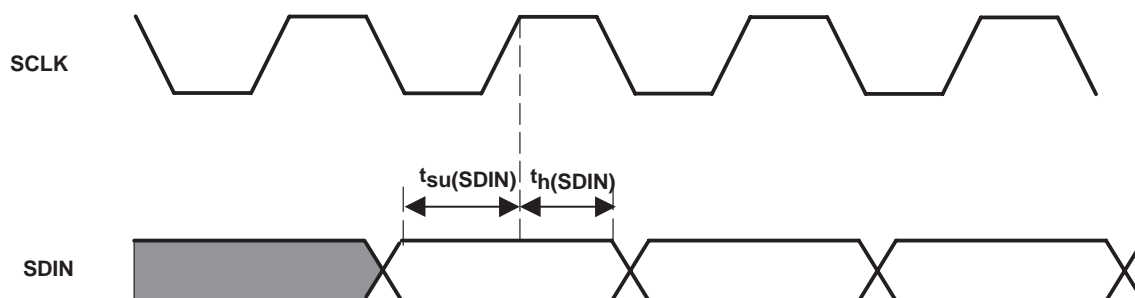
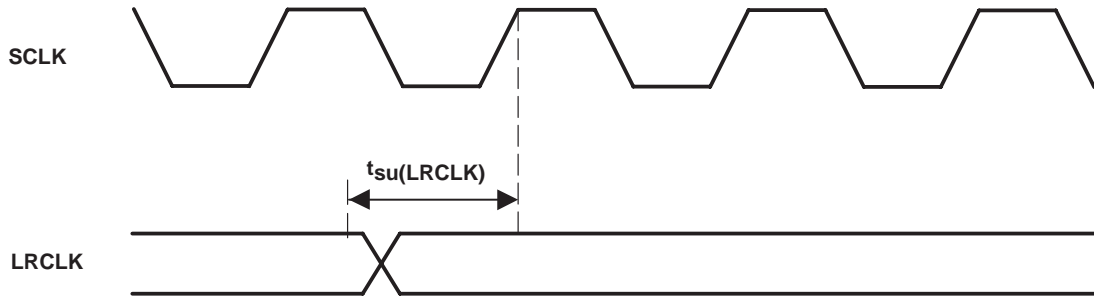

Figure 5–6. Right-Justified, IIS, Left-Justified Serial Protocol Timing



NOTE: Serial data is sampled with the rising edge of SCLK (setup time = 20 ns and hold time = 10 ns).

Figure 5-7. Right, Left, and IIS Serial Mode Timing Requirement

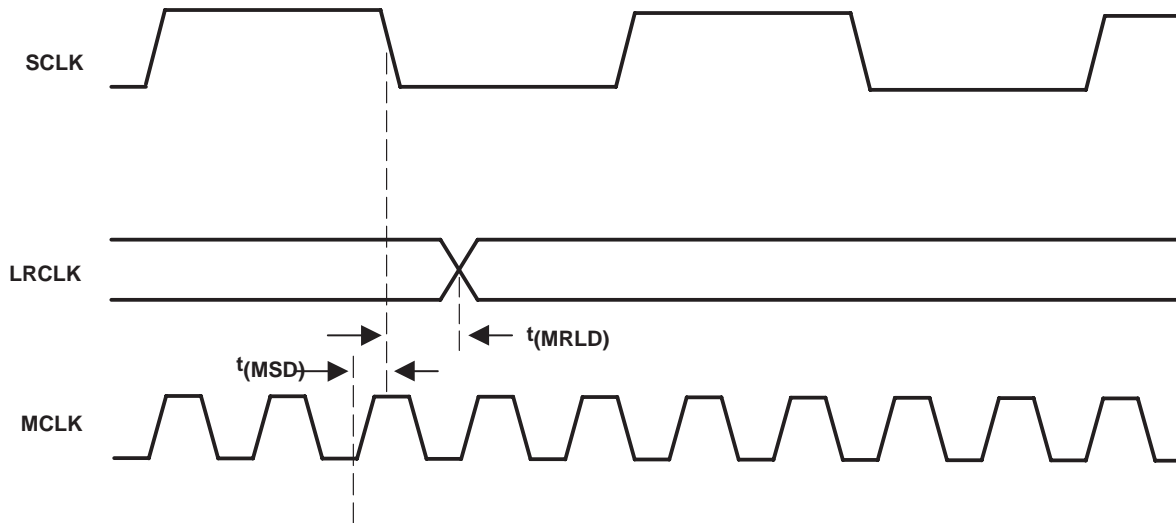

Figure 5-8. Serial Audio Ports Master Mode Timing

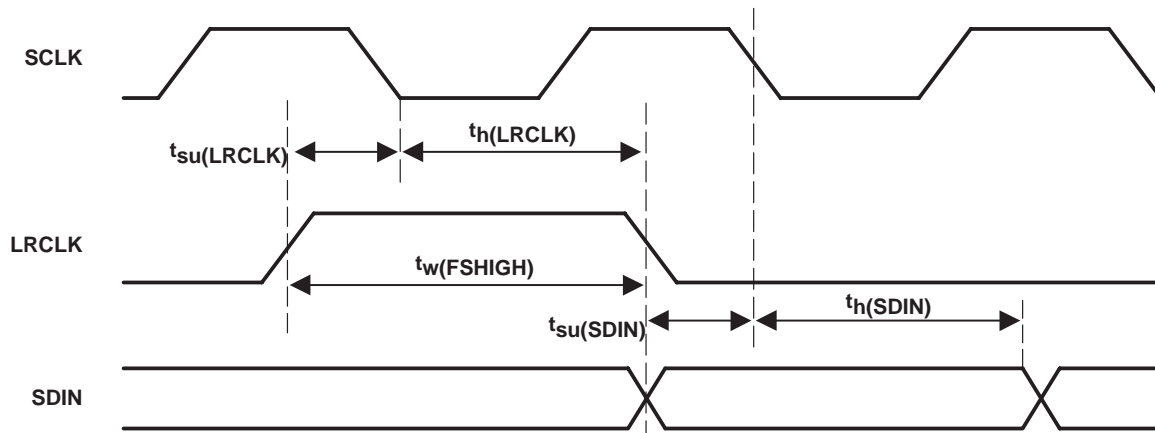

Figure 5-9. DSP Serial Port Timing

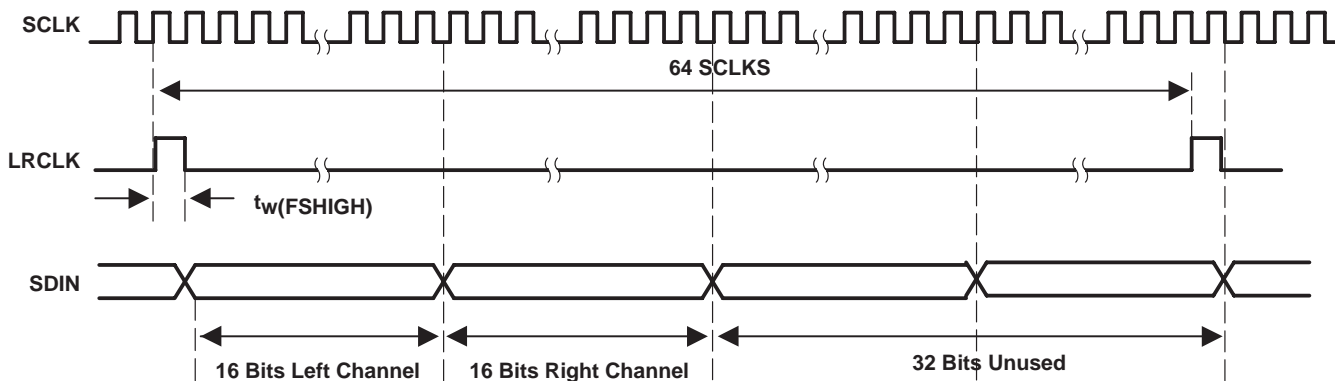

Figure 5–10. DSP Serial Port Expanded Timing

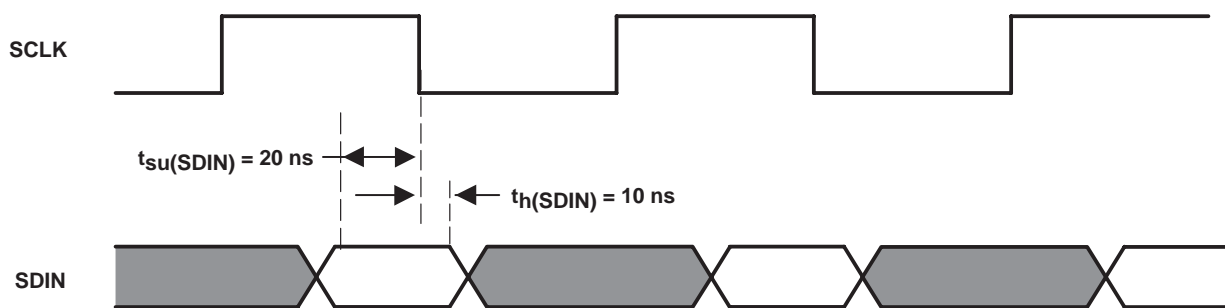

Figure 5–11. DSP Absolute Timing

5.4.3 Serial Control Port—I²C Operation

5.4.3.1 Timing Characteristics for I²C Interface Signals Over Recommended Operating Conditions (Unless Otherwise Noted)

PARAMETER	TEST CONDITIONS	STANDARD MODE		FAST MODE		UNIT
		MIN	MAX	MIN	MAX	
f _{SCL} Frequency, SCL		0	100	0	400	kHz
t _{w(H)} Pulse duration, SCL high		4		0.6		μs
t _{w(L)} Pulse duration, SCL low		4.7		1.3		μs
t _r Rise time, SCL and SDA			1000		300	ns
t _f Fall time, SCL and SDA			300		300	ns
t _{su1} Setup time, SDA to SCL		250		100		ns
t _{h1} Hold time, SCL to SDA		0		0		ns
t _(buf) Bus free time between stop and start condition		4.7		1.3		μs
t _{su2} Setup time, SCL to start condition		4.7		0.6		μs
t _{h2} Hold time, start condition to SCL		4		0.6		μs
t _{su3} Setup time, SCL to stop condition		4		0.6		μs
C _L Load capacitance for each bus line			400		400	pF

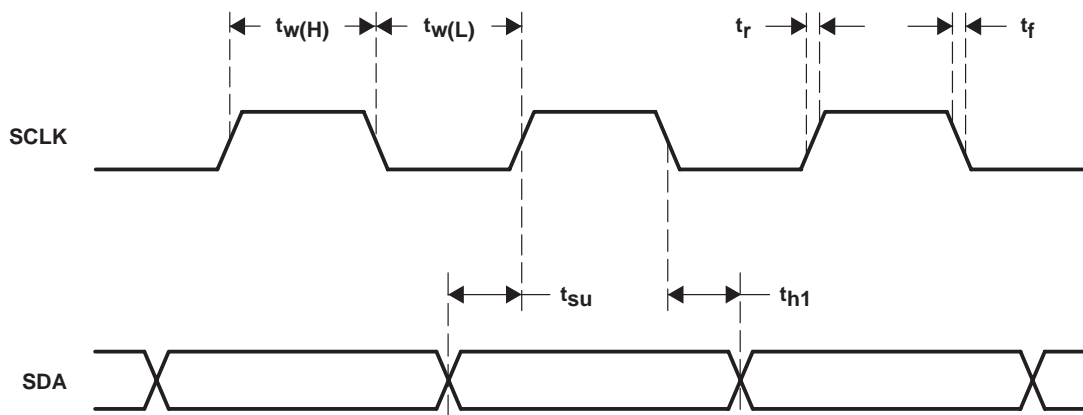

Figure 5–12. SCL and SDA Timing

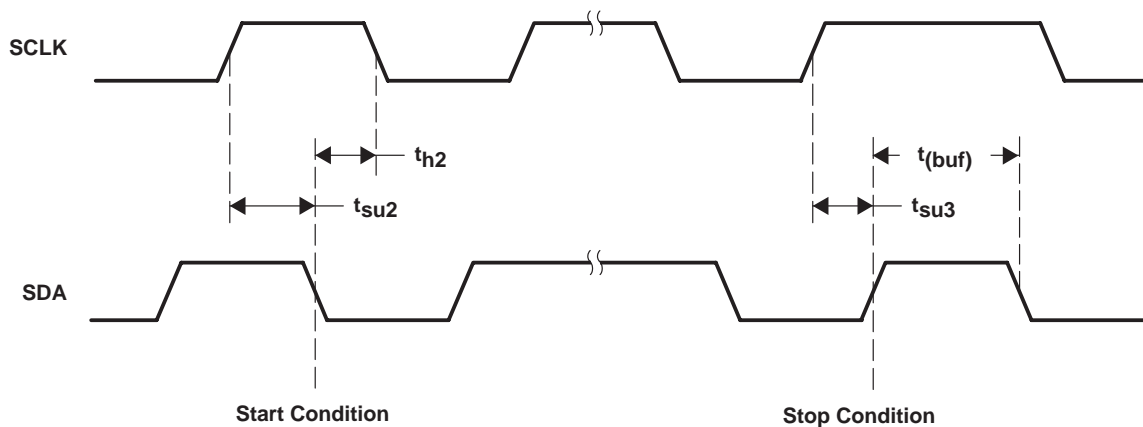

Figure 5–13. Start and Stop Conditions Timing

6 Application Information

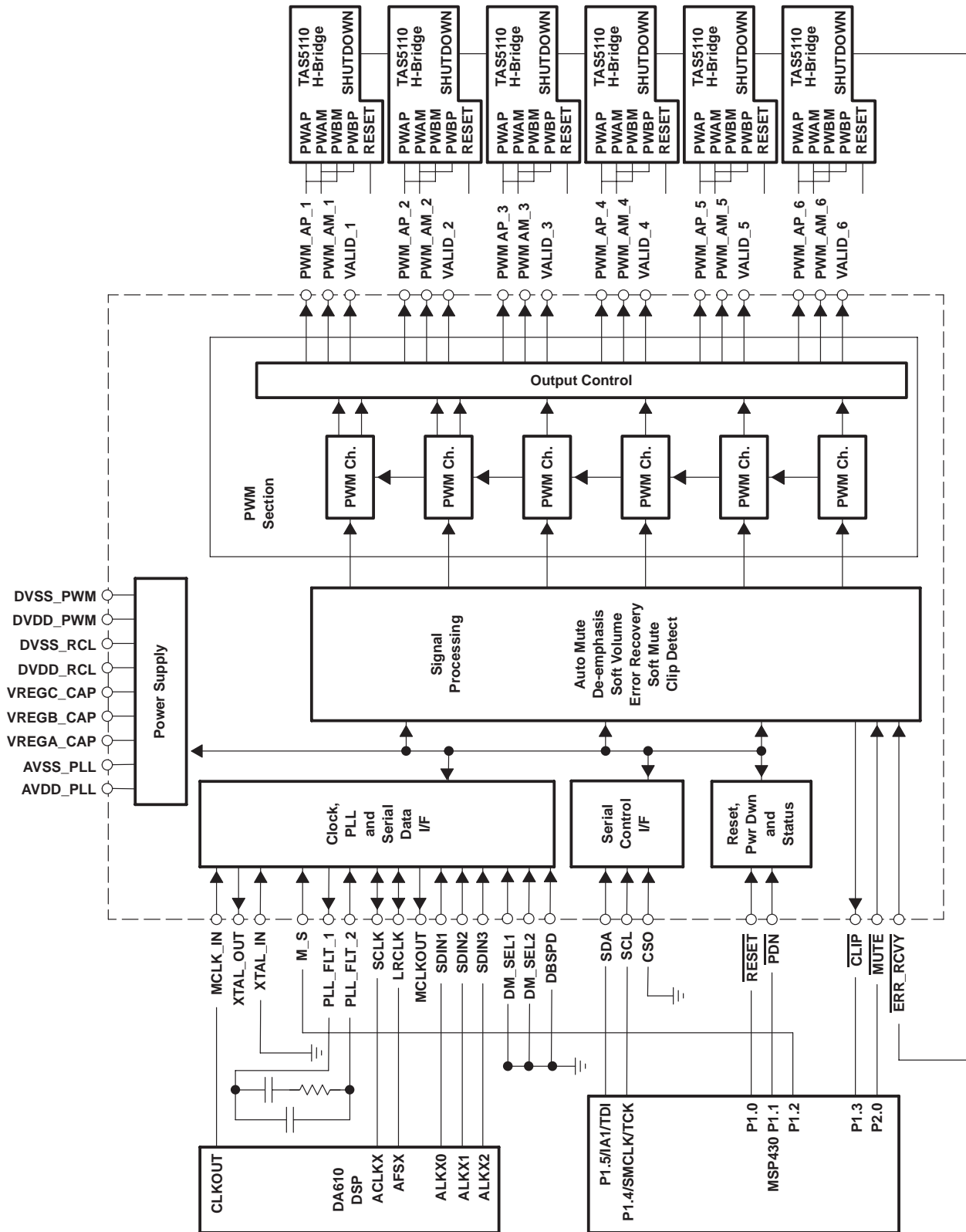

Figure 6–1. Typical TAS5036B Application

6.1 Serial Audio Interface Clock Master and Slave Interface Configuration

6.1.1 Slave Configuration

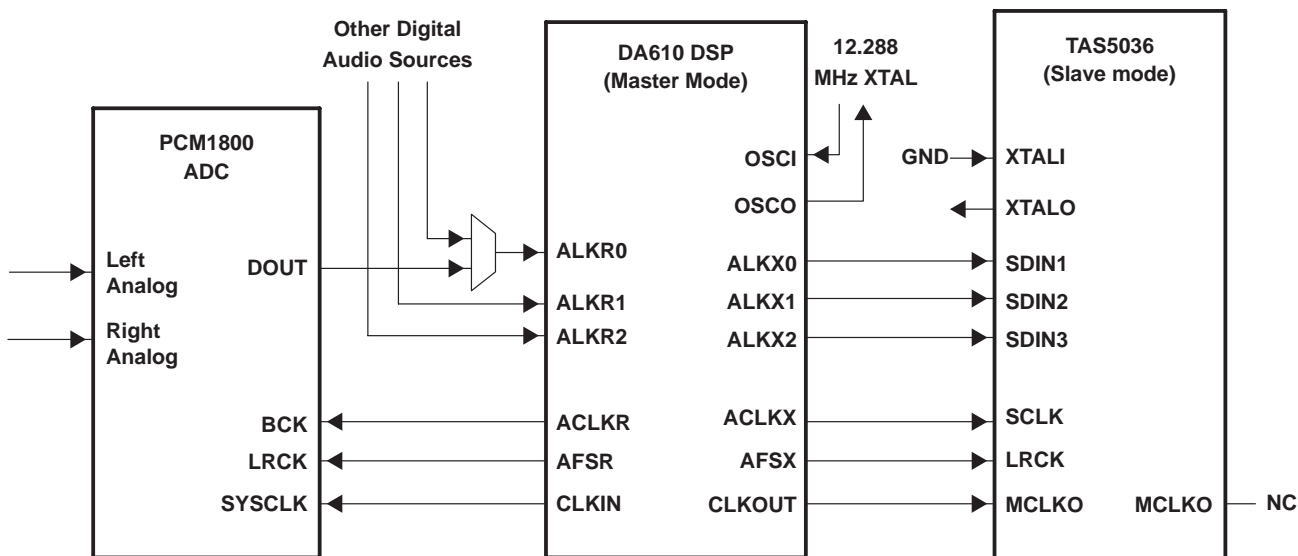

Figure 6-2. TAS5036B Serial Audio Port—Slave Mode Connection Diagram

6.1.2 Master Configuration

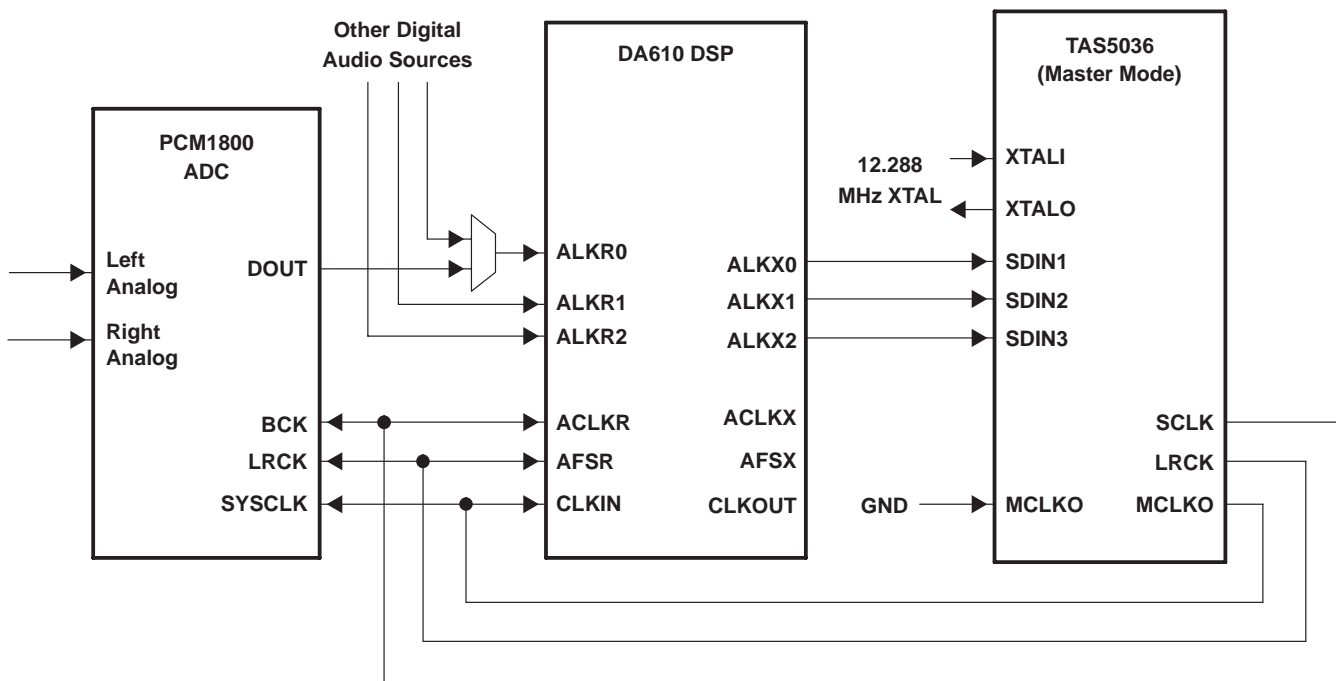
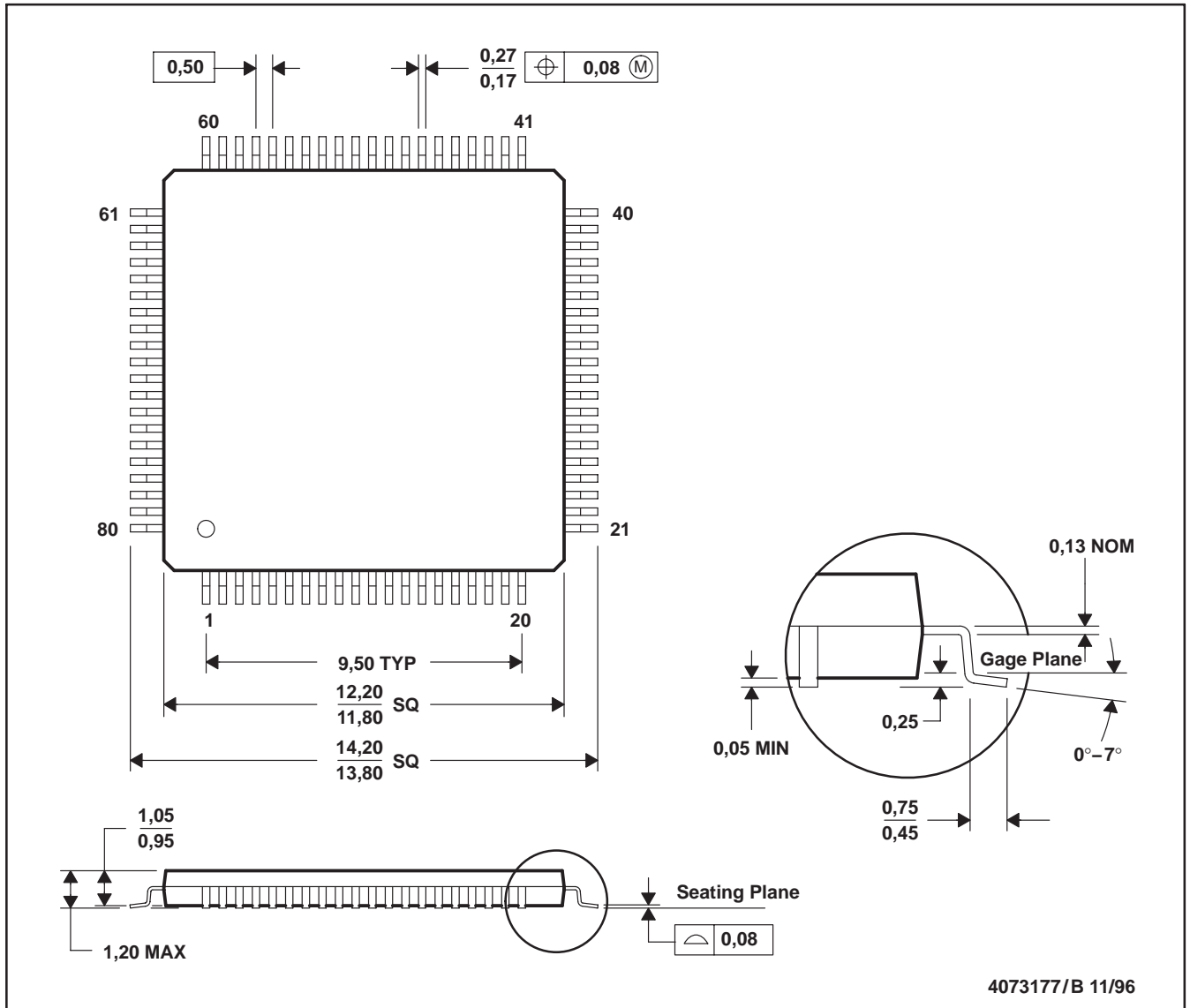

Figure 6-3. TAS5036B Serial Audio Port—Master Mode Connection Diagram

7 Mechanical Data

PFC (S-PQFP-G80)

PLASTIC QUAD FLATPACK



- NOTES: A. All linear dimensions are in millimeters.
 B. This drawing is subject to change without notice.
 C. Falls within JEDEC MS-026

Appendix A—Volume Table

VOLUME SETTING	REGISTER VOLUME (BIN)	GAIN dB
	D7 – D0	
249	11111001	24
248	11111000	23.5
247	11110111	23
246	11110110	22.5
245	11110101	22
244	11110100	21.5
243	11110011	21
242	11110010	20.5
241	11110001	20
240	11110000	19.5
239	11101111	19
238	11101110	18.5
237	11101101	18
236	11101100	17.5
235	11101011	17
234	11101010	16.5
233	11101001	16
232	11101000	15.5
231	11100111	15
230	11100110	14.5
229	11100101	14
228	11100100	13.5
227	11100011	13
226	11100010	12.5
225	11100001	12
224	11100000	11.5
223	11011111	11
222	11011110	10.5
221	11011101	10
220	11011100	9.5
219	11011011	9
218	11011010	8.5
217	11011001	8
216	11011000	7.5
215	11010111	7
214	11010110	6.5
213	11010101	6
212	11010100	5.5
211	11010011	5
210	11010010	4.5
209	11010001	4
208	11010000	3.5
207	11001111	3
206	11001110	2.5

VOLUME SETTING	REGISTER VOLUME (BIN)	GAIN dB
	D7 – D0	
205	11001101	2
204	11001100	1.5
203	11001011	1
202	11001010	0.5
201	11001001	0
200	11001000	-0.5
199	11000111	-1
198	11000110	-1.5
197	11000101	-2
196	11000100	-2.5
195	11000011	-3
194	11000010	-3.5
193	11000001	-4
192	11000000	-4.5
191	10111111	-5
190	10111110	-5.5
189	10111101	-6
188	10111100	-6.5
187	10111011	-7
186	10111010	-7.5
185	10111001	-8
184	10111000	-8.5
183	10110111	-9
182	10110110	-9.5
181	10110101	-10
180	10110100	-10.5
179	10110011	-11
178	10110010	-11.5
177	10110001	-12
176	10110000	-12.5
175	10101111	-13
174	10101110	-13.5
173	10101101	-14
172	10101100	-14.5
171	10101011	-15
170	10101010	-15.5
169	10101001	-16
168	10101000	-16.5
167	10100111	-17
166	10100110	-17.5
165	10100101	-18
164	10100100	-18.5
163	10100011	-19
162	10100010	-19.5

VOLUME SETTING	REGISTER VOLUME (BIN)	GAIN dB
	D7 – D0	
161	10100001	-20
160	10100000	-20.5
159	10011111	-21
158	10011110	-21.5
157	10011101	-22
156	10011100	-22.5
155	10011011	-23
154	10011010	-23.5
153	10011001	-24
152	10011000	-24.5
151	10010111	-25
150	10010110	-25.5
149	10010101	-26
148	10010100	-26.5
147	10010011	-27
146	10010010	-27.5
145	10010001	-28
144	10010000	-28.5
143	10001111	-29
142	10001110	-29.5
141	10001101	-30
140	10001100	-30.5
139	10001011	-31
138	10001010	-31.5
137	10001001	-32
136	10001000	-32.5
135	10000111	-33
134	10000110	-33.5
133	10000101	-34
132	10000100	-34.5
131	10000011	-35
130	10000010	-35.5
129	10000001	-36
128	10000000	-36.5
127	01111111	-37
126	01111110	-37.5
125	01111101	-38
124	01111100	-38.5
123	01111011	-39
122	01111010	-39.5
121	01111001	-40
120	01111000	-40.5
119	01110111	-41
118	01110110	-41.5
117	01110101	-42

VOLUME SETTING	REGISTER VOLUME (BIN)	GAIN dB
	D7 – D0	
116	01110100	-42.5
115	01110011	-43
114	01110010	-43.5
113	01110001	-44
112	01110000	-44.5
111	01101111	-45
110	01101110	-45.5
109	01101101	-46
108	01101100	-46.5
107	01101011	-47
106	01101010	-47.5
105	01101001	-48
104	01101000	-48.5
103	01100111	-49
102	01100110	-49.5
101	01100101	-50
100	01100100	-50.5
99	01100011	-51
98	01100010	-51.5
97	01100001	-52
96	01100000	-52.5
95	01011111	-53
94	01011110	-53.5
93	01011101	-54
92	01011100	-54.5
91	01011011	-55
90	01011010	-55.5
89	01011001	-56
88	01011000	-56.5
87	01010111	-57
86	01010110	-57.5
85	01010101	-58
84	01010100	-58.5
83	01010011	-59
82	01010010	-59.5
81	01010001	-60
80	01010000	-60.5
79	01001111	-61
78	01001110	-61.5
77	01001101	-62
76	01001100	-62.5
75	01001011	-63
74	01001010	-63.5
73	01001001	-64
72	01001000	-64.5

VOLUME SETTING	REGISTER VOLUME (BIN)	GAIN dB
	D7 – D0	
71	01000111	-65
70	01000110	-65.5
69	01000101	-66
68	01000100	-66.5
67	01000011	-67
66	01000010	-67.5
65	01000001	-68
64	01000000	-68.5
63	00111111	-69
62	00111110	-69.5
61	00111101	-70
60	00111100	-70.5
59	00111011	-71
58	00111010	-71.5
57	00111001	-72
56	00111000	-72.5
55	00110111	-73
54	00110110	-73.5
53	00110101	-74
52	00110100	-74.5
51	00110011	-75
50	00110010	-75.5
49	00110001	-76
48	00110000	-76.6
47	00101111	-77
46	00101110	-77.5
45	00101101	-78
44	00101100	-78.5
43	00101011	-79
42	00101010	-79.6
41	00101001	-80.1
40	00101000	-80.6
39	00100111	-81.1
38	00100110	-81.5
37	00100101	-82.1

VOLUME SETTING	REGISTER VOLUME (BIN)	GAIN dB
	D7 – D0	
36	00100100	-82.6
35	00100011	-83
34	00100010	-83.5
33	00100001	-84
32	00100000	-84.6
31	00011111	-85.1
30	00011110	-85.8
29	00011101	-86.1
28	00011100	-86.8
27	00011011	-87.2
26	00011010	-87.5
25	00011001	-88.4
24	00011000	-88.8
23	00010111	-89.3
22	00010110	-89.8
21	00010101	-90.3
20	00010100	-90.9
19	00010011	-91.5
18	00010010	-92.1
17	00010001	-92.8
16	00010000	-93.6
15	00001111	-94.4
14	00001110	-95.3
13	00001101	-96.3
12	00001100	-97.5
11	00001011	-98.8
10	00001010	-100.4
9	00001001	-102.4
8	00001000	-104.9
7	00000111	-108.4
6	00000110	-114.4
5	00000101	MUTE
4	00000100	MUTE
3	00000011	MUTE
2	00000010	MUTE
1	00000001	MUTE
0	00000000	MUTE

PACKAGING INFORMATION

Orderable Device	Status ⁽¹⁾	Package Type	Package Drawing	Pins	Package Qty	Eco Plan ⁽²⁾	Lead/Ball Finish	MSL Peak Temp ⁽³⁾
TAS5036BPFC	NRND	TQFP	PFC	80	96	Green (RoHS & no Sb/Br)	CU NIPDAU	Level-4-260C-72 HR
TAS5036BPFCG4	NRND	TQFP	PFC	80	96	Green (RoHS & no Sb/Br)	CU NIPDAU	Level-4-260C-72 HR
TAS5036BPFCR	NRND	TQFP	PFC	80	1000	Green (RoHS & no Sb/Br)	CU NIPDAU	Level-4-260C-72 HR
TAS5036BPFCRG4	NRND	TQFP	PFC	80	1000	Green (RoHS & no Sb/Br)	CU NIPDAU	Level-4-260C-72 HR

⁽¹⁾ The marketing status values are defined as follows:

ACTIVE: Product device recommended for new designs.

LIFEBUY: TI has announced that the device will be discontinued, and a lifetime-buy period is in effect.

NRND: Not recommended for new designs. Device is in production to support existing customers, but TI does not recommend using this part in a new design.

PREVIEW: Device has been announced but is not in production. Samples may or may not be available.

OBSOLETE: TI has discontinued the production of the device.

⁽²⁾ Eco Plan - The planned eco-friendly classification: Pb-Free (RoHS), Pb-Free (RoHS Exempt), or Green (RoHS & no Sb/Br) - please check <http://www.ti.com/productcontent> for the latest availability information and additional product content details.

TBD: The Pb-Free/Green conversion plan has not been defined.

Pb-Free (RoHS): TI's terms "Lead-Free" or "Pb-Free" mean semiconductor products that are compatible with the current RoHS requirements for all 6 substances, including the requirement that lead not exceed 0.1% by weight in homogeneous materials. Where designed to be soldered at high temperatures, TI Pb-Free products are suitable for use in specified lead-free processes.

Pb-Free (RoHS Exempt): This component has a RoHS exemption for either 1) lead-based flip-chip solder bumps used between the die and package, or 2) lead-based die adhesive used between the die and leadframe. The component is otherwise considered Pb-Free (RoHS compatible) as defined above.

Green (RoHS & no Sb/Br): TI defines "Green" to mean Pb-Free (RoHS compatible), and free of Bromine (Br) and Antimony (Sb) based flame retardants (Br or Sb do not exceed 0.1% by weight in homogeneous material)

⁽³⁾ MSL, Peak Temp. -- The Moisture Sensitivity Level rating according to the JEDEC industry standard classifications, and peak solder temperature.

Important Information and Disclaimer:The information provided on this page represents TI's knowledge and belief as of the date that it is provided. TI bases its knowledge and belief on information provided by third parties, and makes no representation or warranty as to the accuracy of such information. Efforts are underway to better integrate information from third parties. TI has taken and continues to take reasonable steps to provide representative and accurate information but may not have conducted destructive testing or chemical analysis on incoming materials and chemicals. TI and TI suppliers consider certain information to be proprietary, and thus CAS numbers and other limited information may not be available for release.

In no event shall TI's liability arising out of such information exceed the total purchase price of the TI part(s) at issue in this document sold by TI to Customer on an annual basis.

TAPE AND REEL INFORMATION

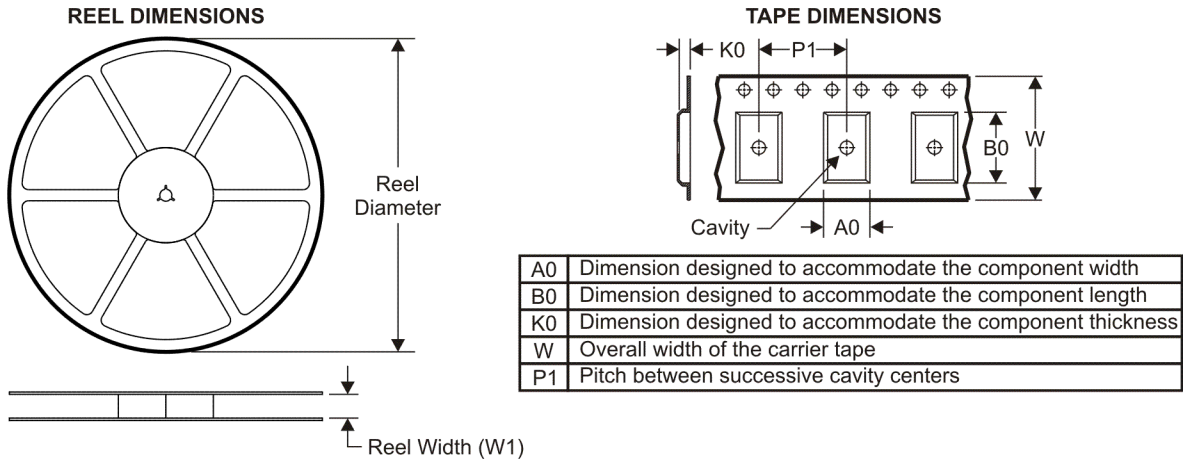

QUADRANT ASSIGNMENTS FOR PIN 1 ORIENTATION IN TAPE



*All dimensions are nominal

Device	Package Type	Package Drawing	Pins	SPQ	Reel Diameter (mm)	Reel Width W1 (mm)	A0 (mm)	B0 (mm)	K0 (mm)	P1 (mm)	W (mm)	Pin1 Quadrant
TAS5036BPFGR	TQFP	PFC	80	1000	330.0	24.4	15.0	15.0	1.5	20.0	24.0	Q2

TAPE AND REEL BOX DIMENSIONS



*All dimensions are nominal

Device	Package Type	Package Drawing	Pins	SPQ	Length (mm)	Width (mm)	Height (mm)
TAS5036BPFCR	TQFP	PFC	80	1000	346.0	346.0	41.0

PFC (S-PQFP-G80)

PLASTIC QUAD FLATPACK

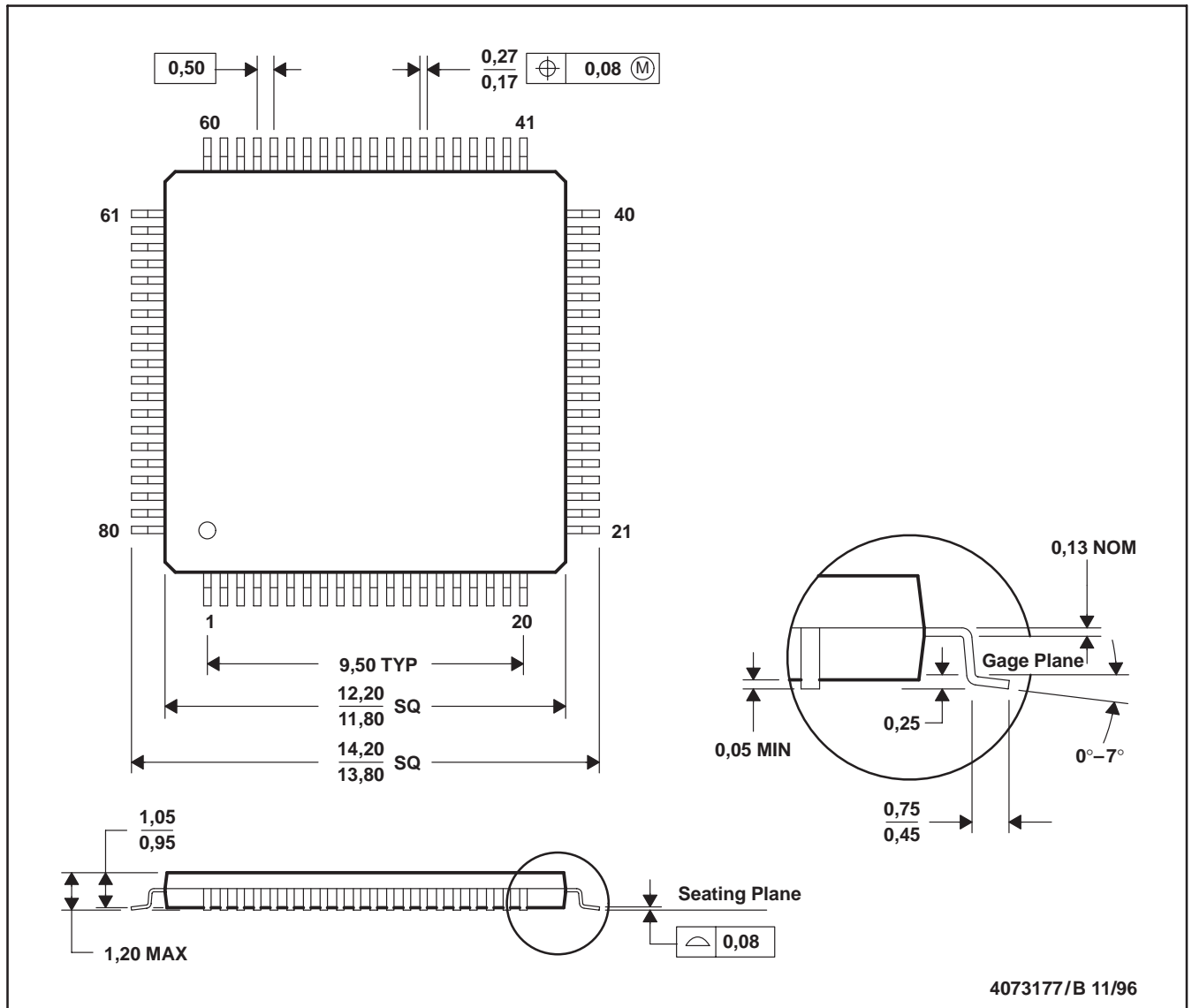

- NOTES: A. All linear dimensions are in millimeters.
 B. This drawing is subject to change without notice.
 C. Falls within JEDEC MS-026